

OPERATING AND SERVICING MANUAL
FOR

MODEL AC-4A AND
AC-4B

DECADE COUNTERS

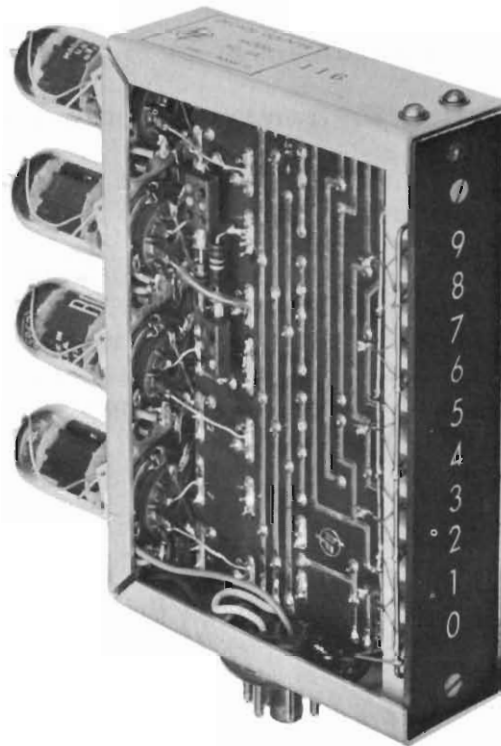

Copyright 1955 by Hewlett-Packard Company

The information contained in this booklet is intended for the operation and maintenance of Hewlett-Packard equipment and is not to be used otherwise or reproduced without the written consent of the Hewlett-Packard Company.

HEWLETT - PACKARD COMPANY
275 PAGE MILL ROAD, PALO ALTO, CALIFORNIA, U. S. A.

0134AB001

NOTE

This manual was written for the AC-4A Decade Counter but also applies to the AC-4B Decade Counter. The appearance and circuit operation of the AC-4A and the AC-4B are identical; the differences in the AC-4B are as follows:

- 1) Upper frequency limit of 220 kc
- 2) Higher current requirement of 18 milliamperes
- 3) Lower input pulse requirement of approx. 60 volts peak
- 4) Different component values (covered in separate parts list and schematic diagram for the AC-4B)

Except for the input voltage requirements (see specifications) the AC-4B is directly interchangeable with the AC-4A. The AC-4B can be used in most cases for emergency replacement for the AC-4A or to increase the maximum counting rate of CP counters utilizing an AC-4A in the units position. However, it is not recommended for normal replacement of the AC-4A.

SPECIFICATIONS

AC-4A

AC-4B

| | | |
|--------------------------|--|---|
| Counting Rate | 120 KC | 220 KC |
| Double-pulse Resolution | 7 μ s | 4 μ s |
| Input Voltage | 80v negative pulse with 1 μ s rise time. (Less amplitude required with faster rise time.) | 55v negative pulse with 1.5 μ s rise time. (Less amplitude required with faster rise time.) |
| Output Voltage | 80v negative pulse. | 80v negative pulse. |
| Reset | To Zero - Open base pin connection or apply positive pulse. To Nine - Apply negative pulse. | To Zero - Open base pin connection or apply positive pulse. To Nine - Apply negative pulse. |
| Staircase Output Voltage | + 135v at count of zero. + 55v at count of nine. 10 steps. | + 135v at count of zero. + 55v at count of nine. 10 steps. |
| Power Supply | 6.3vac \pm 10% at 1.2a. +300vdc at 15 ma. | 6.3vac \pm 10% at 1.2a. +300vdc at 15 ma. |
| Dimensions | 5-5/8" deep x 1-1/4" wide x 6-1/8" high. | 5-5/8" deep x 1-1/4" wide x 6-1/8" high. |
| Mounting | Requires octal socket. | Requires octal socket. |
| Weight | Net 1 lb; shipping, 2 lbs. | Net 1 lb; shipping, 2 lbs. |

SECTION I
GENERAL DESCRIPTION

1-1 DESCRIPTION

The Model AC-4A Decade Counter is a general purpose, plug-in electronic counter that counts electrical pulses applied to its input terminal and indicates the number of the last pulse received in a column of numerals from "0" to "9" on the front panel.

The AC-4A produces one output pulse each time the registered counts steps from "9" to "0", i. e., produces one output pulse for every ten input pulses. Consequently, any desired count storage capacity can be obtained by connecting the units in series and by placing them side by side so that the first units provide the "units" digit, the second unit provides the "tens" digit, and so on. The final answer is then read directly as a number across the row of counter units.

The count is indicated on the panel of the AC-4A by illuminating the correct numeral in the number column with a neon lamp. Engraved numerals and special reflecting surfaces behind the neon lamps insure good readability.

A second output signal, the "Staircase" output, is provided for operating certain types of external indicating devices. This output signal consists of nine equal steps of voltage, one step for each count indicated in the number column.

The AC-4A utilizes etched circuits which provide good production uniformity and very low capacity wiring and result in a very stable, fast counting unit. The open-frame construction lowers operating temperatures and simplifies parts inspection and servicing.

The AC-4A requires 300 volts dc at approximately 15 milliamperes and 6.3 volts ac at 1.2 amperes for operation, neither voltage requiring regulation. The unit plugs into a standard octal socket and is secured by a single mounting screw at the top of the number column.

The AC-4A is directly replaceable with any other plug-in-counter unit used in Hewlett-Packard Electronic Counter instruments, and in addition, it is also directly interchangeable with many similar decade counter units of other manufacturers.

AC-4A 4/2/56 0134A006-1

SECTION II
INSTALLATION

2-1 SOCKET CONNECTIONS

The pins on the octal plug for the AC-4A are listed below with their functions:

- Pin 1 - Pins 1 and 7 receive filament power, 6.3 volts, $\pm 10\%$ 1.2 amperes and should not contain transient pulses of sufficient amplitude to cause erratic counting. Either side of the filament circuit may be grounded externally.
- Pin 2 - Pin 2 provides for resetting the AC-4A to "0" when a new count is to be started. For the AC-4A to count, this pin must be connected to ground through a resistance not more than 750 ohms. To reset the AC-4A to "0" this circuit may be momentarily opened, or a positive pulse of 150 volts peak may be applied to pin 2. (See note 1.)
- Diagrams of typical reset circuits are available from the Hewlett-Packard Company upon request.
- Pin 3 - Pin 3 provides the output signal (input signal $\div 10$) from the AC-4A. The output connection is direct-coupled and has from 50 to 140 volt d-c potential on it. The output signal is a negative-going wave from the 140-volt level to the 50-volt level which occurs when the unit passes the count of "9". The load placed on pin 3 should not be less than 300,000 ohms, or 6000 ohms in series with 100 $\mu\mu\text{f}$. (See OUTPUT WAVEFORM in Maintenance Section - page 12.)
- Pin 4 - Pin 4 receives the d-c operating power, 300-volt dc $\pm 10\%$ at approximately 15 milliamperes. This voltage does not have to be regulated, but it must not contain transient pulses or ripple of sufficient amplitude to produce random counts.
- Pin 5 - Pin 5 receives the input signal to be counted. The AC-4A counts negative-going wave fronts having approximately 80 volts peak amplitude and 1 micro-second rise time. Faster rise times decrease the amplitude required. (See note 2.)

AC-4A 4/2/56 0134A006-1

- Pin 6 - Pin 6 is the Ground and B - connection and is connected to chassis or ground bus.
- Pin 7 - Filament circuit, see Pin 1.
- Pin 8 - Pin 8 provides the "Staircase" output voltage. The staircase voltage is proportional to the digit displayed and may be used to operate a remote indicating device. The open circuit voltage varies from +138 volts for a displayed count of "0" to +54 volts for a displayed count "9" in approximately equal steps. (See STAIRCASE OUTPUT waveform in Section 4.)

The staircase output circuit has an internal impedance of approximately 700,000 ohms and the output voltage depends upon the external load connected to this circuit. The load connected to this circuit does not affect the normal counting of the unit.

CAUTION

Suitable precautions must be taken to prevent coupling transient voltages through any of the external connections to the AC-4A, or erratic counting may result.

NOTE 1

The displayed count on the AC-4A may be reset to "0" manually with a switch or electronically by pulse. A pulse used for reset must have a fast rise and slow decay; pulse width is unimportant. The rise time must be approximately one μ sec 150 volts as applied to 750 ohms maximum between pin 2 and ground. The unit can be reset to "9" with a negative reset pulse.

NOTE 2

The -hp- Amplitude Discriminator Unit, Model 522B-58B generates a suitable driving pulse for the AC-4A, and has a maximum sensitivity of 0.2 volt on any waveform. Complete details of this plug-in-unit are available from the Hewlett-Packard Company.

SECTION III
THEORY OF OPERATION

3-1 GENERAL

The AC-4A Decade Counter plug-in unit consists of four bi-stable multivibrators (binaries) and a bank of 10 neon lighted numerals on the front panel. As the binaries sense the input pulses, certain combinations of voltages are set up between halves of the binaries which light the appropriate neon lamp for each pulse.

The state of the first binary determines whether an odd or even numbered lamp will be lighted by applying one necessary voltage to the even lamps, or to the odd lamps. The other voltage is obtained as the difference-voltage existing across two specific halves of two different binaries. As subsequent input pulses are received the difference-voltage lighting the lamps proceeds from one pair of binaries to the next, lighting subsequent lamps.

The four binaries are connected in cascade so the output from the first is fed to the input of the second, and so on. Each binary is designed to respond only to negative-going input pulses. Each binary produces alternately positive and negative output pulses for a series of negative input pulses. Since the next binary senses only the negative pulses, the effect is to divide by two.

With four such binaries 16 input pulses would be required to obtain one negative output pulse (overall division would be 16). However, by the use of two feedback loops 6 extra "counts" are added within the unit so that only 10 input pulses are required to obtain one negative output pulse to make the total division 10. The feedback circuits used in counters are not to be confused with feedback circuits used in amplifier design. Counter feedback circuits are used only to apply a pulse from one of the binaries in a chain to another in the same chain. If the feedback pulse is of the correct polarity, it will trigger the binary, producing the same result as additional pulses at the input. The action of an individual binary is described below followed by a discussion of the operation of four such binaries connected in series.

3-2 THE BI-STABLE MULTIVIBRATOR, OR BINARY

The circuit of a typical bi-stable multivibrator is shown in Figure 1. This circuit has two stable states; one, with "A" side conducting, two, with "B" side conducting. All input pulses are applied equally to both the "A" and "B" sides, however, only negative going pulses can start the switching action.

AC-4A 4/2/46 0134A006-1

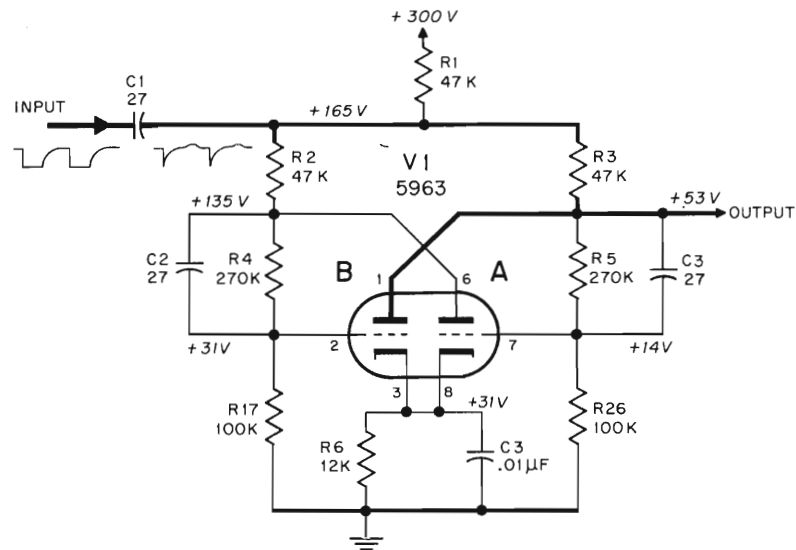

Fig. 1. Circuit of binary used in AC-4A Counter Unit

Prior to receiving an input pulse a binary rests in one of its two stable states; one side is conducting, one side is not. The high positive voltage at the plate of the non-conducting tube maintains a high charge on the coupling capacitor to the grid of the conducting tube, while the low plate voltage on the conducting tube maintains only a small charge on the capacitor to the grid of the non-conducting tube.

An input signal is applied to a point in the plate load resistors at R1 which is common to the plate loads of both sides of the binary. This pulse lowers the plate voltage of both tubes, but lowers the plate voltage of the non-conducting tube by almost the full value of the input pulse, whereas the plate voltage of the conducting tube is only slightly affected as it was already at a very low value. Consequently, the negative input pulse coupled from the plate of the non-conducting tube to the grid of the conducting tube will be large; the negative pulse coupled from the plate of the conducting tube to the grid of the non-conducting tube will be very small and is of no importance. A positive input pulse following the same path has no affect upon the grid of the conducting tube and causes no switching action.

The negative input pulse, for a portion of its duration, holds both sides of the binary in a state of non-conduction, and applies a high negative bias to the grid of the previously conducting tube (essentially reversing the relative grid bias for the two halves of the binary). Consequently, when the input pulse is ended, the capacitor to the grid of the previously non-conducting stage and the high plate voltage to which it is now connected cause this grid to go positive very quickly, before

the opposite capacitor can return from its potential far beyond cutoff. The binary has thus returned to a state opposite to that which it held prior to receiving the negative input pulse.

A strong, sharp output pulse is obtained from one plate circuit and coupled to the next binary. The output pulse is positive when the output half of the binary is switched out of conduction, and negative when it is switched into conduction. The amplitude of the output pulses from the 2nd, 3rd and 4th binaries in the AC-4A are equal, and should be approximately 82 volts (from +53 to +135), while the output from the 1st binary is approximately 110 volts, (from +62 to +172).

3-3 OPERATION OF FOUR CASCADED BINARIES

The operation of four binaries connected in cascade and the operation of the neon lighting circuits is described in the following paragraphs with the aid of the diagram in Figure 2. In these diagrams, the waveforms are the d-c potential at the output of each binary. The actuating pulse that is applied to the next binary consists of the rise and decay portions of the waveform shown due to being differentiated by the coupling capacitor.

Diagram A shows the waveforms obtained from a system of four binaries with no feedback. The top row represents the pulses applied to the input, and each subsequent row is the output of a succeeding binary. Waveforms are oriented in relation to the frequency applied to the input. Reading from left to right, each down-going line is a negative pulse which causes the next binary to switch its state. Each up-going line in the waveform is a positive pulse and is without effect. As shown, one positive output pulse is obtained after 8 input pulses and one negative output pulse after 16 input pulses. Such a system would require a column of 16 numbers for the readout, a complex system to read if more than one counter is used.

A more useful indicating system, "0" through "9", can be obtained when the division ratio of the set of four binaries is made to be 10 instead of 16. The readout can then be a direct reading decimal number when more than one counter unit is used, one beside the other. To make the system produce one output pulse for every ten input pulses (instead of 16) the extra six pulses are effectively supplied internally by feeding the required pulses from one binary to another. Diagram B shows such a system in operation. Two feedback paths are used, the first one retriggers the second binary and positions it two input pulses farther along. The second feedback path retriggers the third binary and positions it four input pulses farther along, thus the effect of six additional input pulses is duplicated within the unit to make the unit divide by ten.

Diagram C shows how the readout of 10 neon lighted numbers are made to light in their proper sequence. As input pulses enter, they cause the first binary to continually switch from one state to the other. One

AC-4A 4/2/46 0134A006-1

013-4A002-1

AC-4A 7/13/55

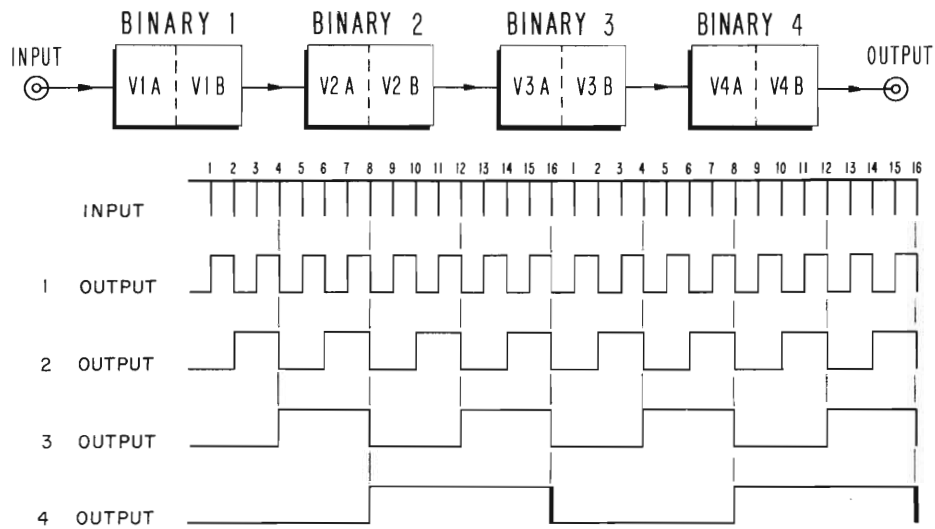

(A)

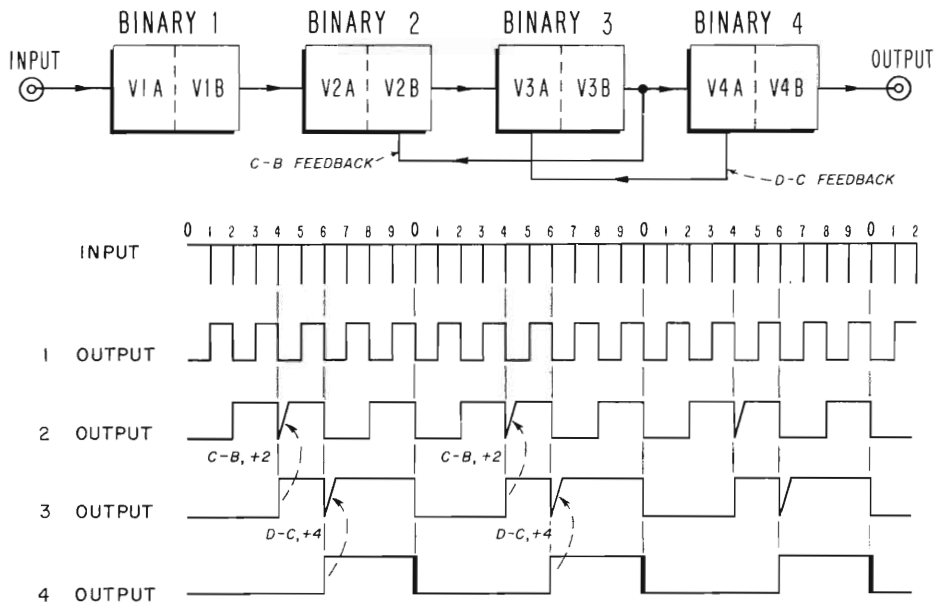

(B)

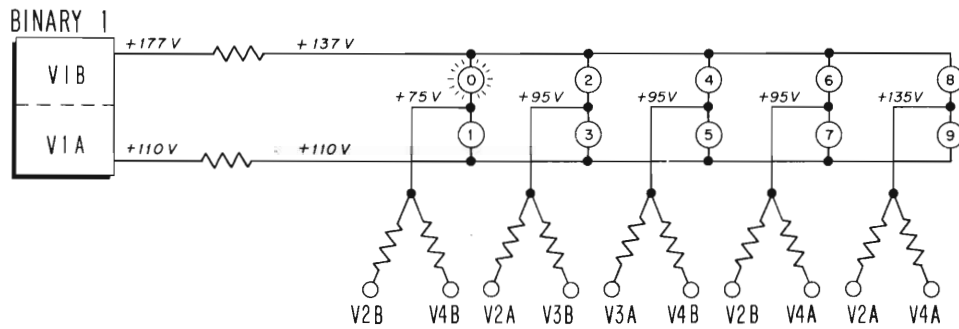

(C)

Fig. 2. Output Waveforms of Each Binary in a 4-Binary System:
 (a) Without feedback to divide by 16
 (b) With feedback to divide by 10
 (c) The lighted numeral readout system

half of the binary is connected to one side of all the even numbered lamps. The other half is connected to one side of all the odd numbered lamps. As the binary switches back and forth it alternately supplies one needed voltage to light the odd, then the even numbered lamps. The difference voltage that determines which odd or even lamp is lighted is obtained from combinations of the various halves of the remaining three binaries, and consists of a resultant voltage when two different binary halves are combined. Three resultant voltages are possible: when both halves are conducting, when both halves are non-conducting and when one is conducting and one is not. Only when both halves are conducting and the voltage is at its lowest is the voltage difference between this combination and that established by the input binary sufficient to light a neon. This voltage of approximately 75 volts gradually moves down the bank of neons shown in the diagram as succeeding input pulses switch the binaries and the odd and even lamps are alternately given the necessary voltage.

AC-4A 4/2/56 0134A006-1

SECTION IV

SERVICING THE AC-4A PLUG-IN COUNTER UNIT

4-1 GENERAL

A majority of failures in counter units can be remedied by tube replacement. Systematically replace one tube at a time to prevent masking other possible circuit failures. If a tube is replaced without improvement in operation, return the original tube to its socket.

Any AC-4A Counter may be exchanged with any other AC-4A Counter without adjustment or change in operation; therefore to determine if a counter is faulty, replace it with one known to be operating properly. An improvement in operation then indicates the original counter to be defective. When exchanging counters in this manner keep in mind that a defective counter can upset the operation of cascaded counters that follow. If several counters seem to operate improperly service the first one in line (see schematic diagram for sequence of counter units.)

4-2 CHECKING AN INDIVIDUAL COUNTER UNIT AT LOW SPEED

Some failures can be analyzed by applying single pulses to a counter unit and observing the counting sequence that results. Figure 3 shows a circuit which will apply a reliable pulse for low-speed operation of the AC-4A Counter. Ten pulses should light each numeral in the column in its correct sequence to complete one cycle of operation. A failure may be indicated by a number lighting in an incorrect sequence or by some unstable state such as one or more numbers flashing on and off.

If the counting sequence is incorrect, but the Counter still has ten stable indications for ten pulses applied, first check the lamp connections and the printed wiring for short circuits then check for a defective lamp which does not light with the normal applied voltage.

If the counter has 12 or 16 stable states one or both of the two feedback networks is open.

If the counter has less than 10 stable states one of the four tubes can be defective. Replace one tube at a time and check for correct operation.

The following chart shows various incorrect indications obtained when making a low-speed operational check and gives the circuit most likely to be at fault. The counter may also be analyzed by measuring the voltages and waveforms throughout the circuit and comparing the measurement indications against the ideal waveforms and the voltages on the schematic diagrams.

TABLE I

| RESETS TO | COUNTING CYCLE | FAULTY CIRCUIT |
|-----------|--|--------------------------------|
| 0 | 0, 1, 8, 9, then repeats 6, 7, 8, 9 | V3 |
| 0 | 0, 2, 4, 6, 8 | V1 |
| 0 | 0, 1, 2, 3, 4, 5 | V4 or output circuit grounded. |
| 0 | 0, 1, 2, 3, 6, 7, 8 & 2, 9 & 3 | V3 |
| 0 | 0, 1, 2, 3, 4, 5, 4, 5, 6, 7, 8, 9, | Feedback between V2 and V3. |
| 0 | 0, 1, 2, 3, 4, 5, 6, 7, 8 & 2, 9 & 3, 8, 9 | Feedback between V4 and V3. |
| 0 | 0, 1, 2, 3, 4, 5, 4, 5, 6, 7, 8 & 2, 9 & 3, 6, 7, 8, 9 | Both feedback loops. |
| 1 | Will not count | V1 |
| 2 | 2, 3 | V4 or V2 |
| 4 | 4, 5 | V2 or V3 |
| 6 | 6, 7, 8 & 2, 9 & 3, 8, 9 | V4 |

4-3 CHECKING AN INDIVIDUAL COUNTER AT HIGH SPEED

Some kinds of circuit failures can cause counter units to count incorrectly or fail at high counting rates, particularly approaching 120,000 cps. This type of trouble can sometimes be corrected by the same remedies as for low-speed failures, however, if a failure persists at high counting rates only, the trouble should be analyzed by observing waveforms throughout the circuit, using a high-speed synchroscope. Begin by measuring the output of the first binary and proceed with each succeeding binary. Adjust the

input signal frequency just below and above the frequency where the counting failure occurs and observe the difference in the waveforms at the output of each binary. Compare the oscilloscope patterns with the ideal waveforms shown in Figure 2. The waveform picture which changes as the counting failure appears usually indicates the proceeding circuit in the printed wiring, changing values in resistors, leakage in capacitors, weak tubes, etc. Any part can be replaced with another part having the same value, tolerance and physical size without circuit adjustment or change in unit operation.

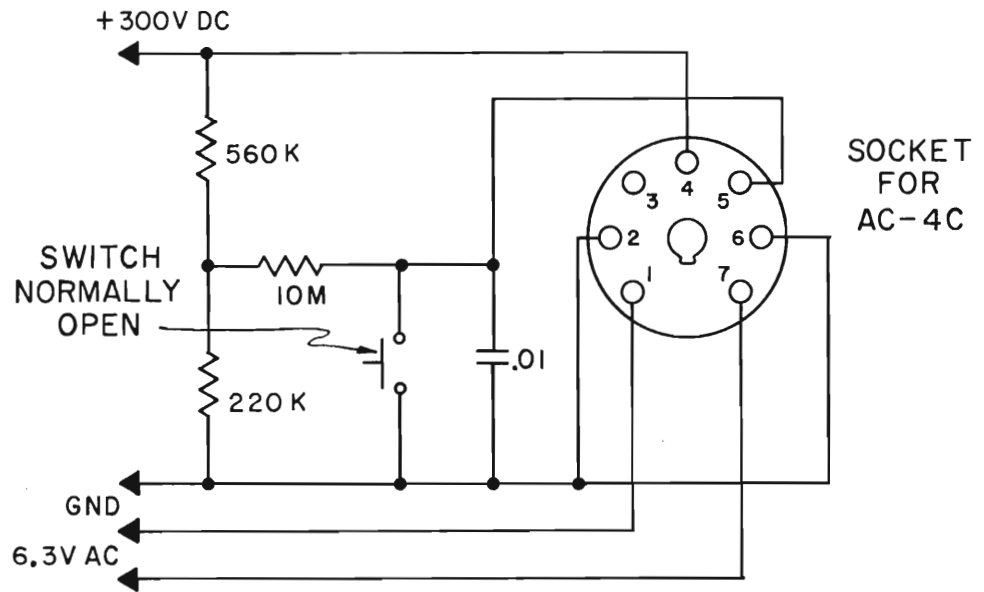

Fig. 3 Manual Trigger Circuit for low-speed testing of the AC-4A

WAVEFORM DATA

Waveform oscillograms taken at the plate of each tube in the AC-4A are shown in the following illustration. The left-hand column shows typical waveforms obtained when the AC-4A is counting low frequencies; the right-hand column when counting frequencies near the upper frequency limit of the AC-4A. At counting rates above 100 kilocycles the waveforms deteriorate in the manner indicated by the difference between the two columns to a point where counting a higher frequency is not possible.

Some circuit failures can cause the waveform deterioration illustrated at frequencies below 100 kc. Such a trouble can be isolated by comparing waveforms obtained from an unsatisfactory counter unit with the waveforms in the illustration. If a binary produces a waveform with excessive deterioration check the tube by replacement with a new tube; check circuit resistances; check the capacity, "Q" and leakage of capacitors, and check for leakage between conductors on the printed circuit board.

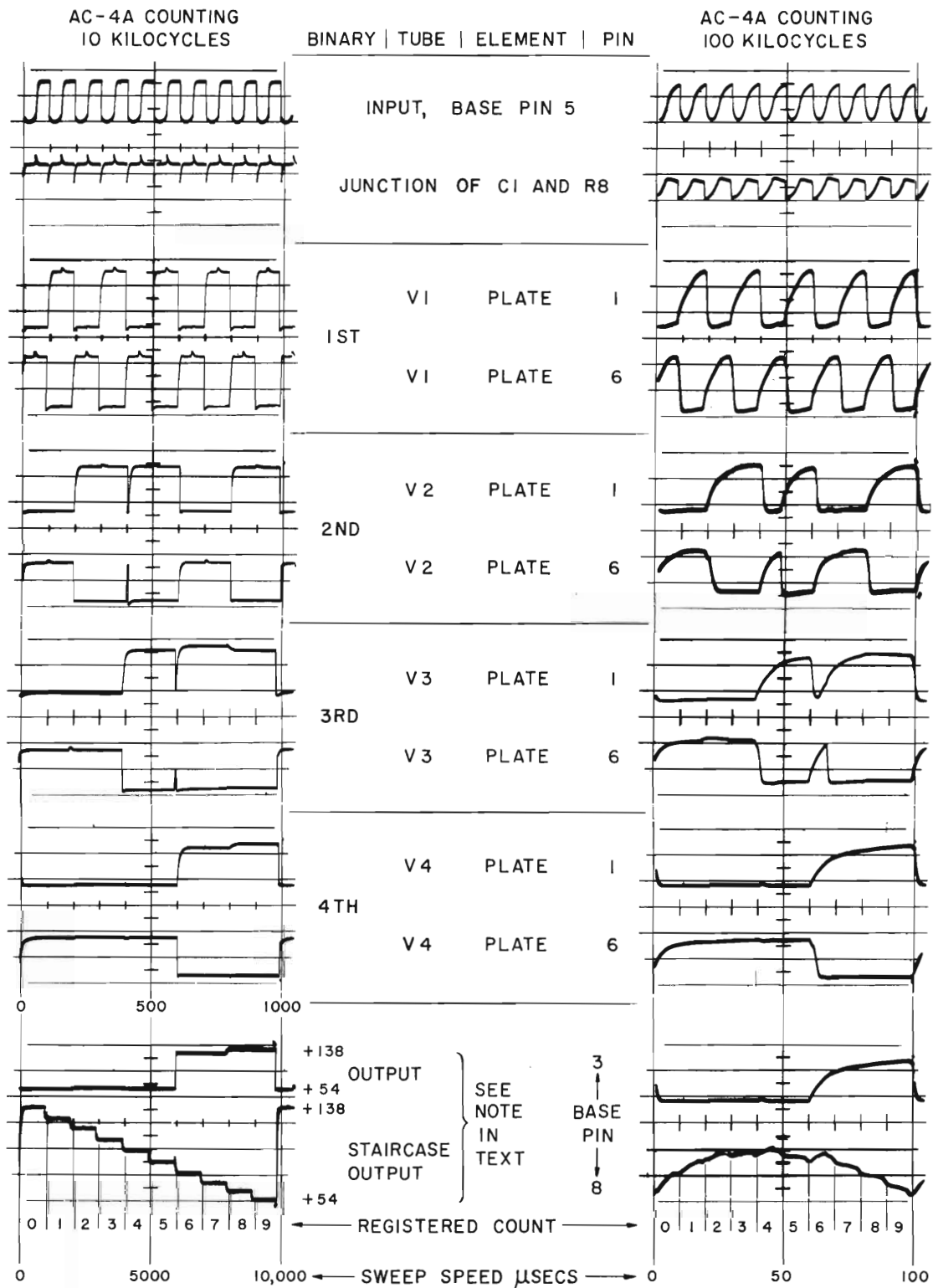

Fig. 4. Oscilloscope waveforms obtained from an AC-4A Decade Counter
(A) counting a low frequency
(B) counting a high frequency

Amplitude Calibration 50 volts/cm unless otherwise noted.
Oscilloscope synchronized with negative portion of the output from the AC-4A

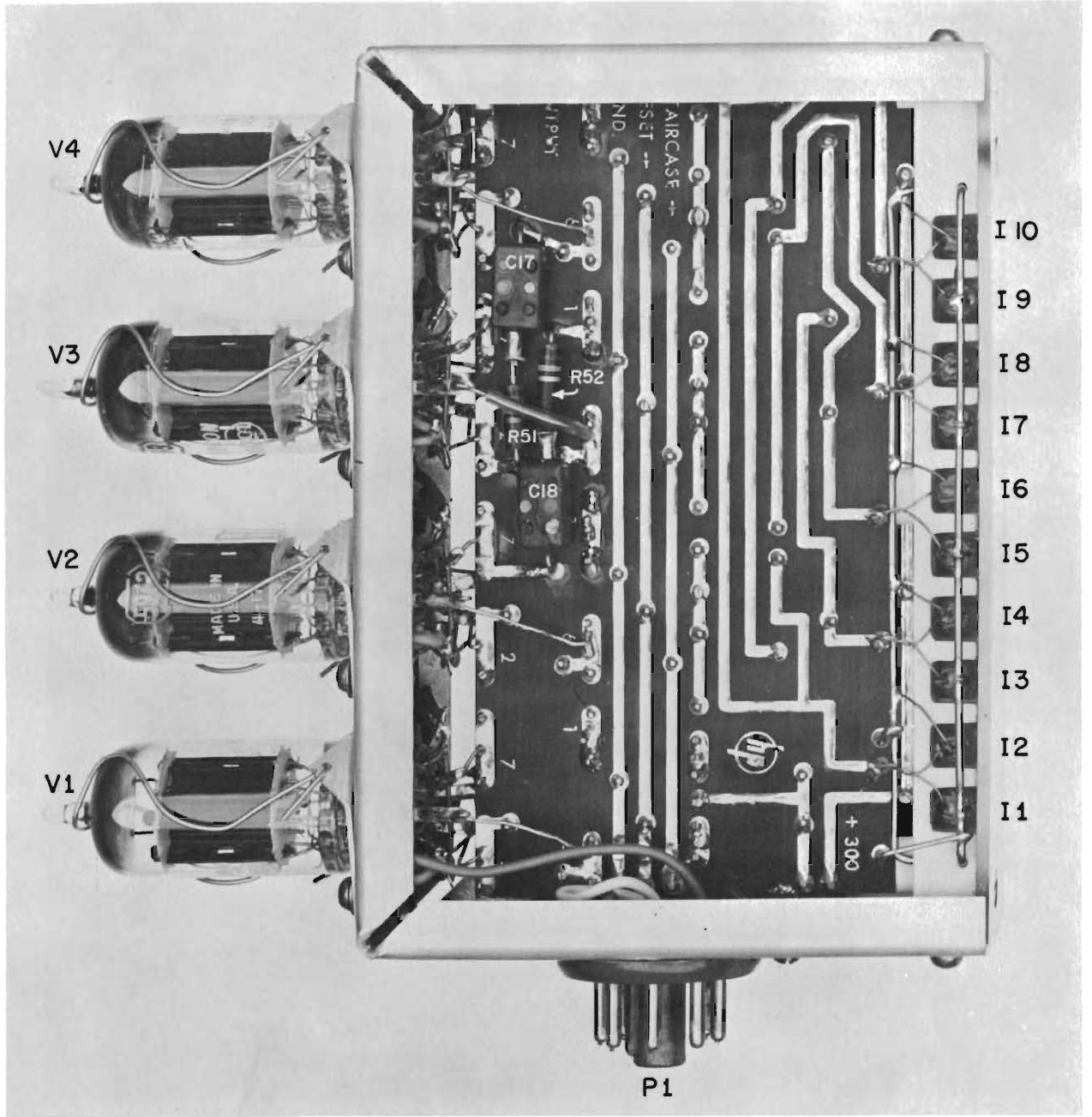

Fig. 5. Left Side of the Model AC-4A

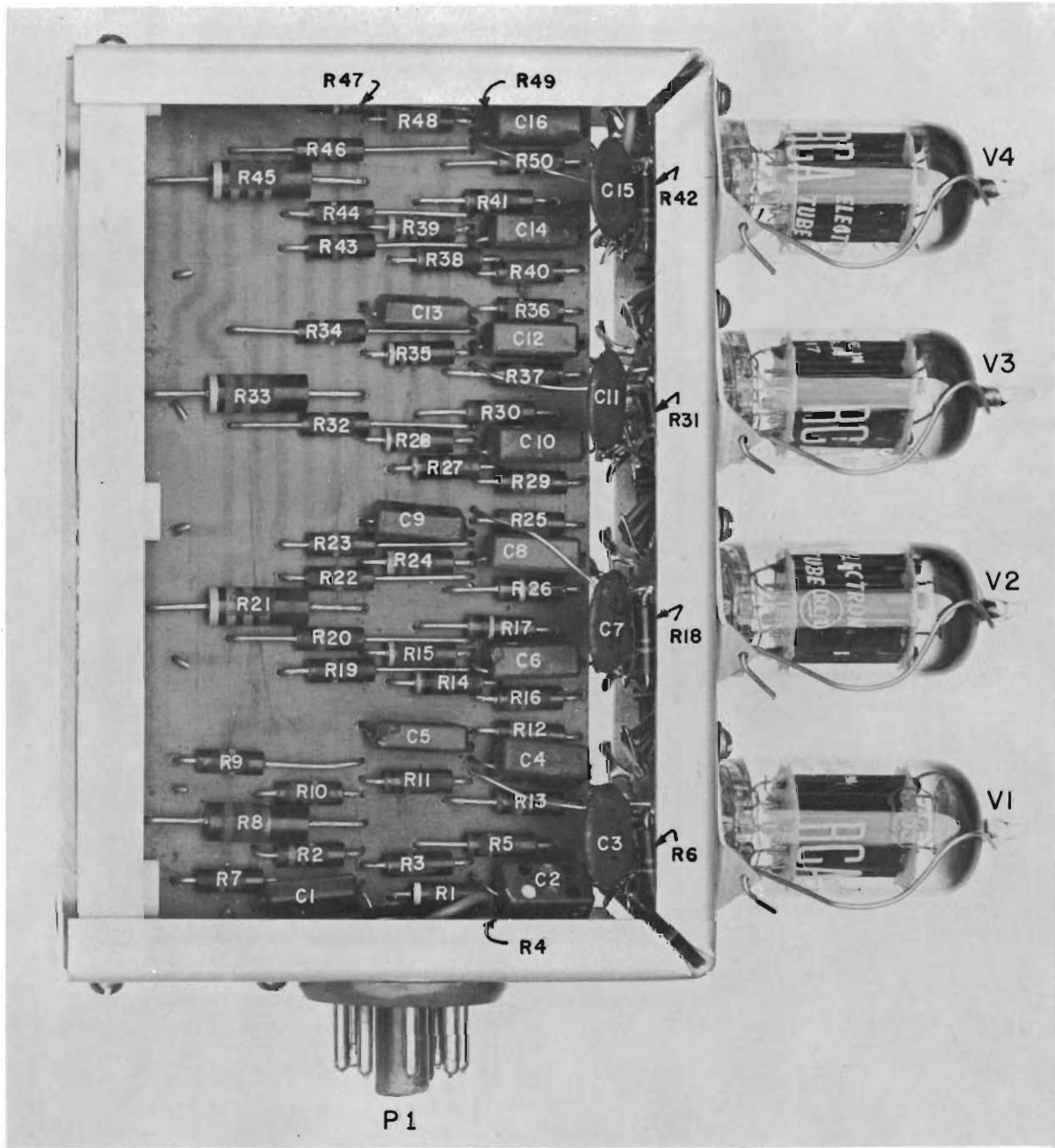
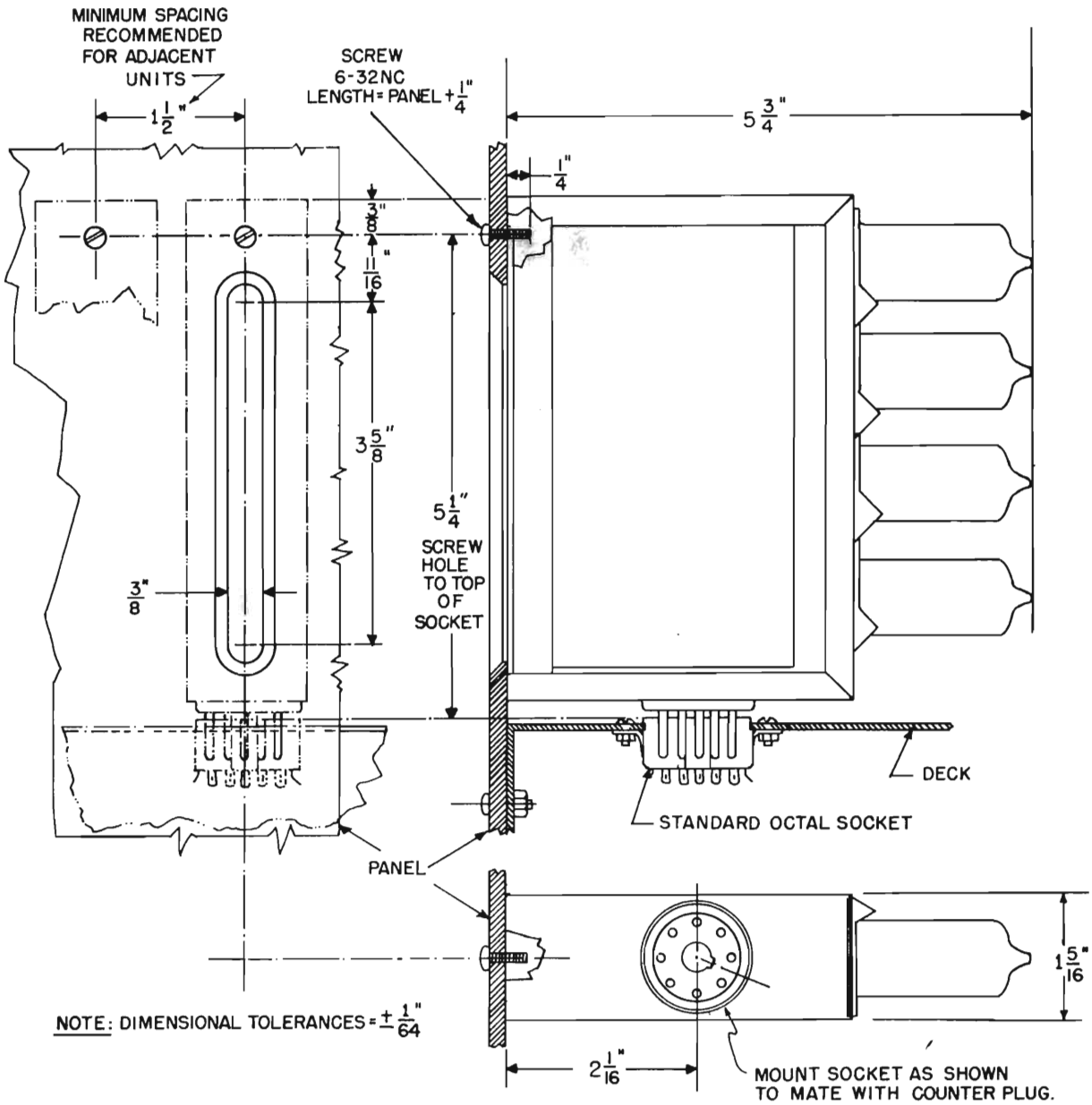

Fig. 6. Right Side of the Model AC-4A



Model AC-4A Mounting Dimensions

Fig. 7

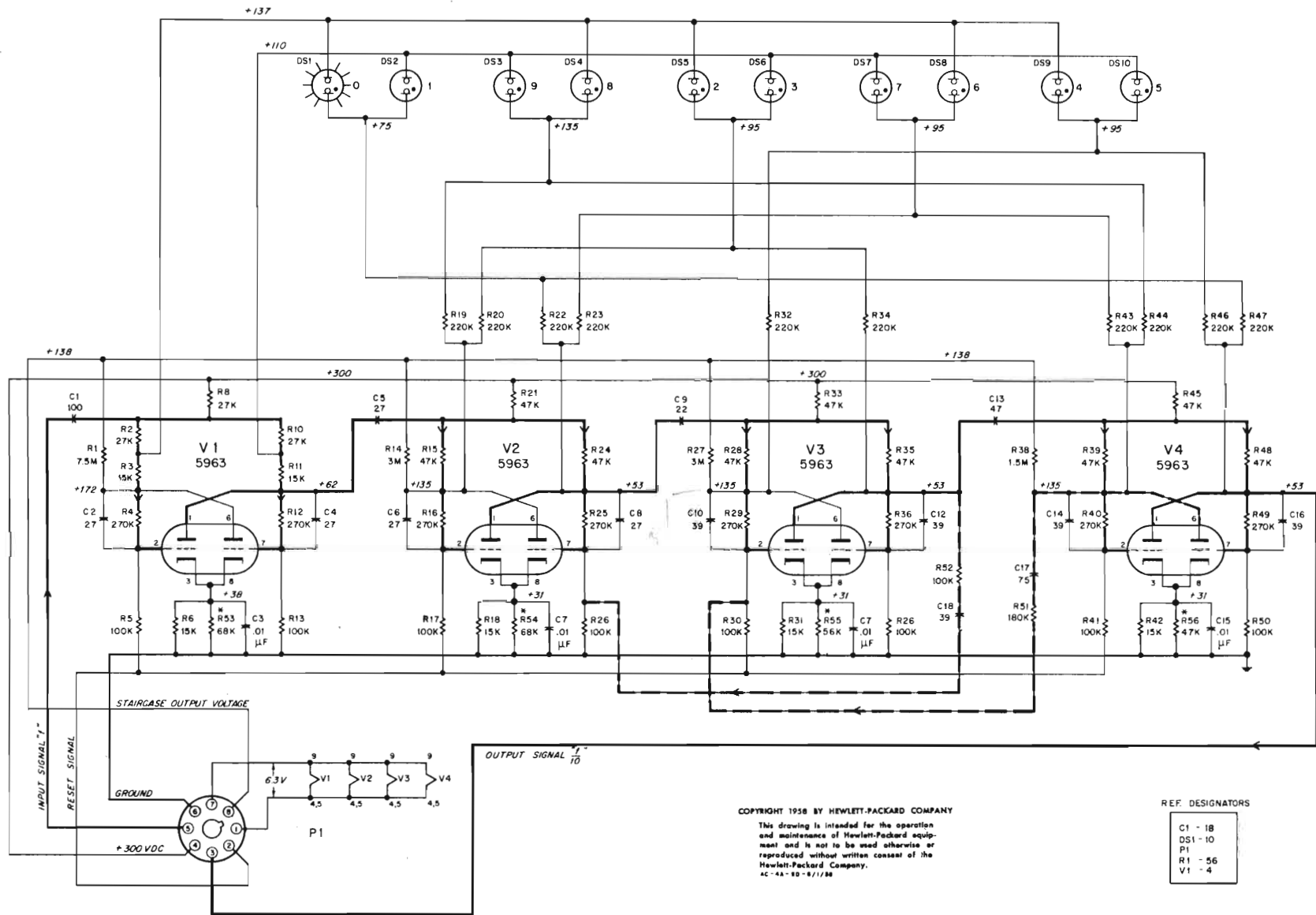
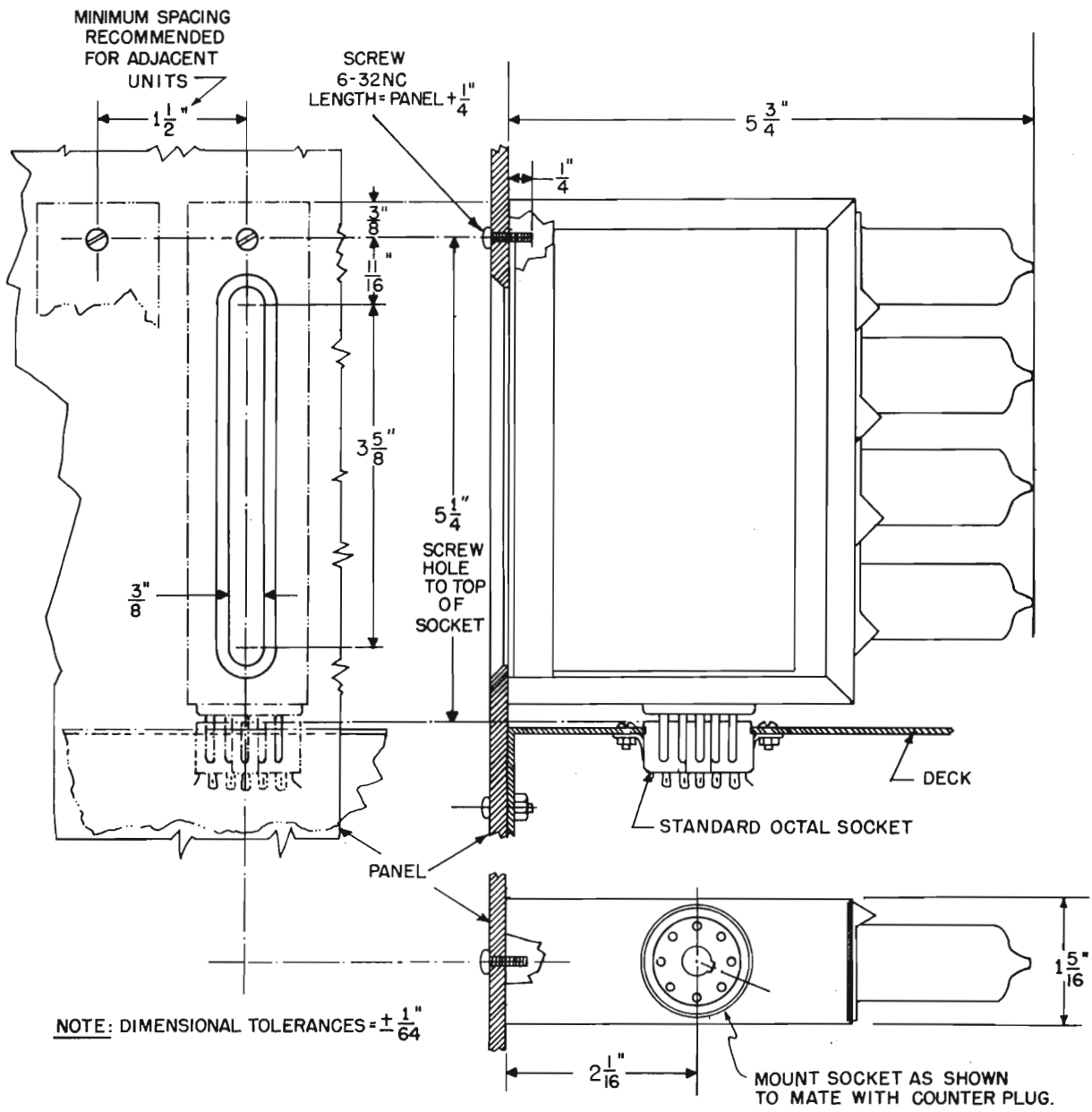

Figure 8. Model AC-4A Decade Counter



Model AC-4A Mounting Dimensions

Fig. 7

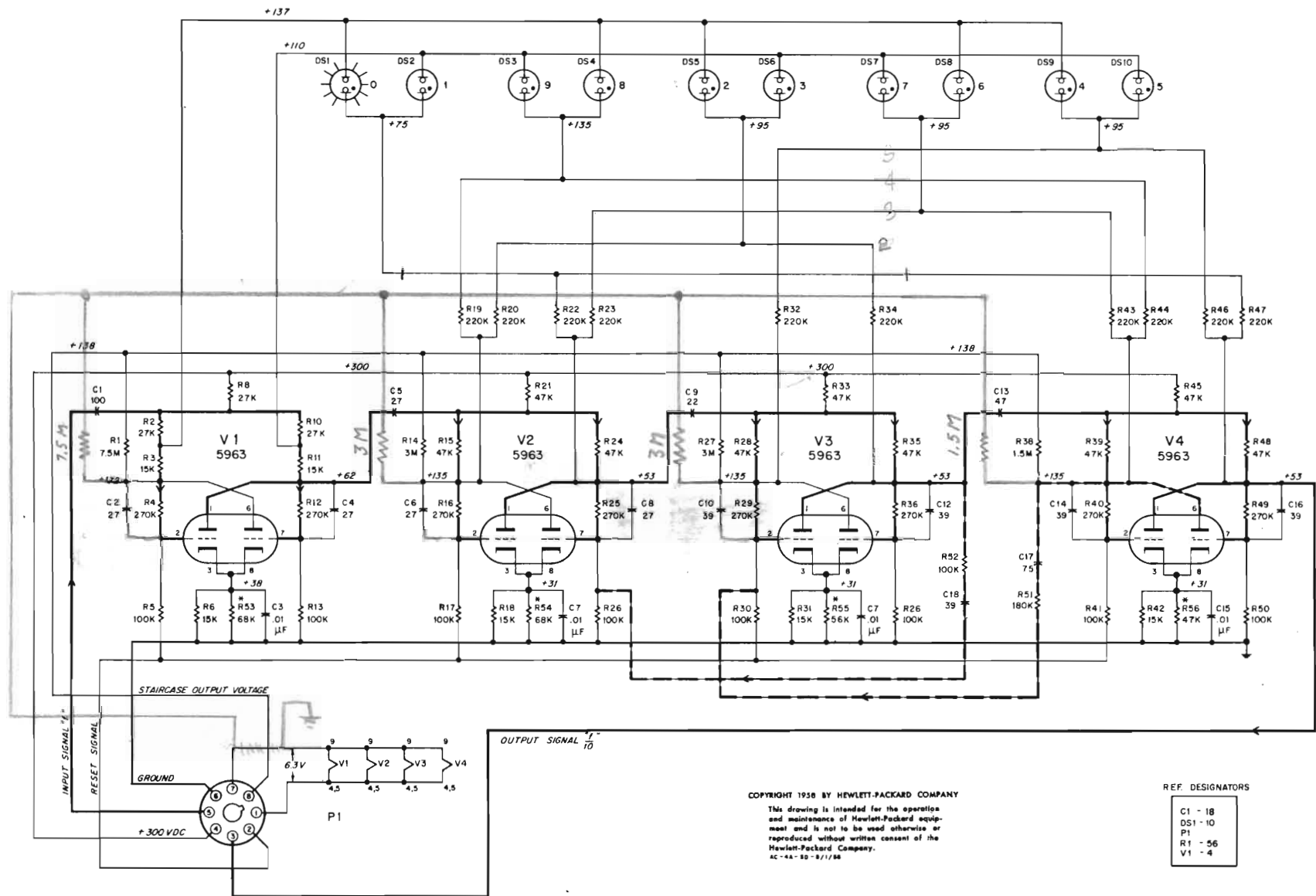

Figure 8. Model AC-4A Decade Counter
 (Modified To Provide Two
 Staircase Voltages)

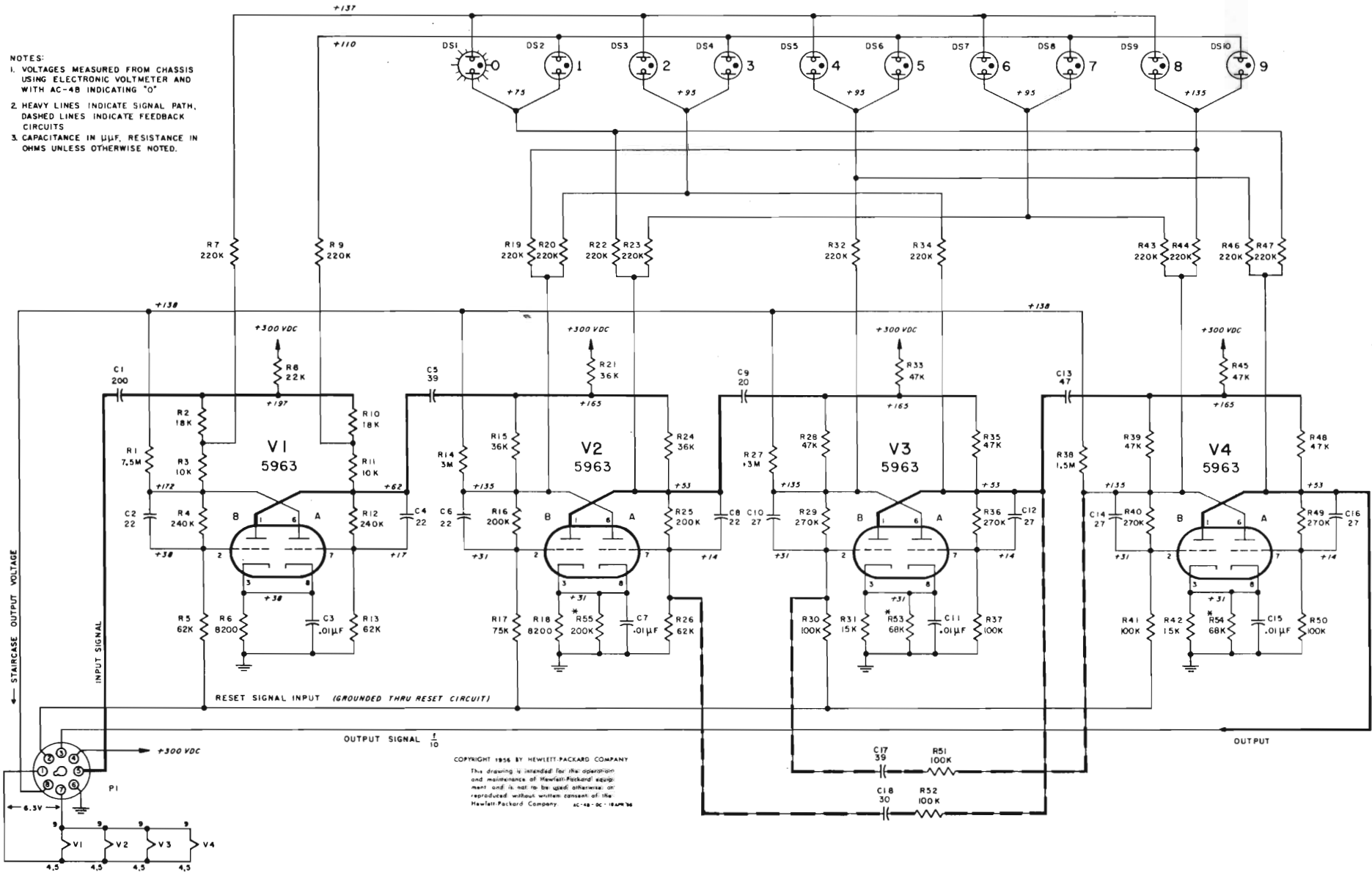

Figure 9. Model AC-4B Decade Counter

SECTION V
TABLE OF REPLACEABLE PARTS
for the AC-4A

NOTE

Any changes in the Table of Replaceable Parts will be listed on a Production Change sheet at the front of this manual.

When ordering parts from the factory always include the following information:

Instrument model number
Serial number
-hp- stock number of part
Description of part

TABLE OF REPLACEABLE PARTS

| CIRCUIT REF. | DESCRIPTION, MFR. * & MFR. DESIGNATION | STOCK NO. | # | | | |
|---------------|--|------------------|---|--|--|--|
| | <u>MODEL AC-4A</u> | | | | | |
| C1 | Capacitor: fixed, mica, 100 μf , $\pm 5\%$, 300 vdcw | V* 14-76 | 1 | | | |
| C2 | Capacitor: fixed, mica, 27 μf , $\pm 5\%$, 300 vdcw | Z* 14-78 | 5 | | | |
| C3 | Capacitor: fixed, ceramic, .01 μf , tol. -0%, +100%, 1000 vdcw | CC* 15-43 | 4 | | | |
| C4, 5, 6 | Same as C2 | | | | | |
| C7 | Same as C3 | | | | | |
| C8 | Same as C2 | | | | | |
| C9 | Capacitor: fixed, mica, 22 μf , $\pm 5\%$, 300 vdcw | V* 14-69 | 1 | | | |
| C10 | Capacitor: fixed, mica, 39 μf , $\pm 5\%$, 300 vdcw | V* 14-70 | 5 | | | |
| C11 | Same as C3 | | | | | |
| C12 | Same as C10 | | | | | |
| C13 | Capacitor: fixed, mica, 47 μf , $\pm 5\%$, 300 vdcw | V* 14-74 | 1 | | | |
| C14 | Same as C10 | | | | | |
| C15 | Same as C3 | | | | | |
| C16 | Same as C10 | | | | | |
| C17 | Capacitor: fixed, mica, 75 μf , $\pm 5\%$, 300 vdcw | V* 14-75 | 1 | | | |
| C18 | Same as C10 | | | | | |
| DS1 thru DS10 | Lamp, glow: 1/25 W, starting voltage 90 VDC (paired, aged) | HP* AC-4A-8 | 5 | | | |
| P1 | Connector, male: octal | HH* 125-31 | 1 | | | |
| R1 | Resistor: fixed, composition, 7.5 megohms, $\pm 5\%$, 1/2 W | B* 23- 7.5M-5 | 1 | | | |
| R2 | Resistor: fixed, composition, 27,000 ohms, $\pm 5\%$, 1/2 W | R* 23- 27KR-5 | 2 | | | |

* See "List of Manufacturers Code Letters For Replaceable Parts Table".

Total quantity used in the instrument.

TABLE OF REPLACEABLE PARTS

| CIRCUIT REF. | DESCRIPTION, MFR. * & MFR. DESIGNATION | Ⓢ STOCK NO. | # | | | |
|---------------------|--|--------------------|----------|--|--|--|
| R3 | Resistor: fixed, composition, 15,000 ohms, ±5%, 1/2 W R* | 23- 15KR-5 | 2 | | | |
| R4 | Resistor: fixed, composition, 270,000 ohms, ±5%, 1/2 W B* | 23- 270K-5 | 8 | | | |
| R5 | Resistor: fixed, composition, 100,000 ohms, ±5%, 1/2 W B* | 23- 100K-5 | 9 | | | |
| R6 | Resistor: fixed, composition, 15,000 ohms, ±5%, 1/2 W B* | 23- 15K-5 | 4 | | | |
| R7 | Resistor: fixed, composition, 220,000 ohms, ±5%, 1/2 W B* | 23- 220K-5 | 12 | | | |
| R8 | Resistor: fixed, composition, 27,000 ohms, ±5%, 1 W B* | 24-27K -5 (C) | 1 | | | |
| R9 | Same as R7 | | | | | |
| R10 | Same as R2 | | | | | |
| R11 | Same as R3 | | | | | |
| R12 | Same as R4 | | | | | |
| R13 | Same as R5 | | | | | |
| R14 | Resistor: fixed, deposited carbon, 3 megohms, ±1%, 1/2 W NN* | 33-3M | 2 | | | |
| R15 | Resistor: fixed, composition, 47,000 ohms, ±5%, 1/2 W R* | 23- 47KR-5 | 6 | | | |
| R16 | Same as R4 | | | | | |
| R17 | Same as R5 | | | | | |
| R18 | Same as R6 | | | | | |
| R19, 20 | Same as R7 | | | | | |
| R21 | Resistor: fixed, composition, 47,000 ohms, ±5%, 1 W R* | 24- 47KR-5 | 2 | | | |
| R22, 23 | Same as R7 | | | | | |
| R24 | Same as R15 | | | | | |
| R25 | Same as R4 | | | | | |

* See "List of Manufacturers Code Letters For Replaceable Parts Table".
Total quantity used in the instrument.

TABLE OF REPLACEABLE PARTS

| CIRCUIT REF. | DESCRIPTION, MFR. * & MFR. DESIGNATION | Ⓢ STOCK NO. | # | | | |
|--------------|---|-------------|------------------|---|--|--|
| R26 | Same as R5 | | | | | |
| R27 | Same as R14 | | | | | |
| R28 | Same as R15 | | | | | |
| R29 | Same as R4 | | | | | |
| R30 | Same as R5 | | | | | |
| R31 | Same as R6 | | | | | |
| R32 | Same as R7 | | | | | |
| R33 | Same as R21 | | | | | |
| R34 | Same as R7 | | | | | |
| R35 | Same as R15 | | | | | |
| R36 | Same as R4 | | | | | |
| R37 | Same as R5 | | | | | |
| R38 | Resistor: fixed, deposited carbon, 1.5 megohms, ±1%, 1/2 W | BV* | 33-1.5M | 1 | | |
| R39 | Same as R15 | | | | | |
| R40 | Same as R4 | | | | | |
| R41 | Same as R5 | | | | | |
| R42 | Same as R6 | | | | | |
| R43, 44 | Same as R7 | | | | | |
| R45 | Resistor: fixed, composition, 47,000 ohms, ±5%, 1 W | B* | 24-47K -5 (C) | 1 | | |
| R46, 47 | Same as R7 | | | | | |
| R48 | Same as R15 | | | | | |
| R49 | Same as R4 | | | | | |
| R50 | Same as R5 | | | | | |

* See "List of Manufacturers Code Letters For Replaceable Parts Table".
Total quantity used in the instrument.

TABLE OF REPLACEABLE PARTS

| CIRCUIT REF. | DESCRIPTION, MFR. * & MFR. DESIGNATION | Ⓢ STOCK NO. | # | | | |
|----------------------|---|----------------|---|--|--|--|
| R51 | Resistor: fixed, composition, 180,000 ohms, ±10%, 1/2 W B* | 23-180K | 1 | | | |
| R52 | Same as R5 | | | | | |
| R53, 54 | Resistor: fixed, composition, 68,000 ohms, ±10%, 1/2 W Electrical value adjusted at factory B* | 23-68K | 2 | | | |
| R55 | Resistor: fixed, composition 56,000 ohms, ±10%, 1/2 W Electrical value adjusted at factory B* | 23-56K | 1 | | | |
| R56 | Resistor: fixed, composition, 47,000 ohms, ±5%, 1/2 W Electrical value adjusted at factory B* | 23-47K-5 | 1 | | | |
| V1, 2, 3, 4 | Tube, electron: 5963 ZZ* | 212-5963 | 4 | | | |
| <u>MISCELLANEOUS</u> | | | | | | |
| | Clamp, tube: 1" Universal Metal | 140-12 | 4 | | | |
| | Lamp, single: neon, aged and tested | HP* AC-4A-9 | 1 | | | |
| | Plate, numeral | HP* AC-4A-6 | 1 | | | |
| | Socket, tube: 9 contact | AE* 120-10 | 4 | | | |

* See "List of Manufacturers Code Letters For Replaceable Parts Table".

Total quantity used in the instrument.

TABLE OF REPLACEABLE PARTS
for the AC-4B

NOTE

Any changes in the Table of Replaceable Parts will be listed on a Production Change sheet at the front of this manual.

When ordering parts from the factory always include the following information:

Instrument model number
Serial number
-hp- stock number of part
Description of part

TABLE OF REPLACEABLE PARTS

| CIRCUIT REF. | DESCRIPTION, MFR. * & MFR. DESIGNATION | STOCK NO. | # | | | |
|--------------------|---|-----------|---|--|--|--|
| <u>MODEL AC-4B</u> | | | | | | |
| C1 | Capacitor: fixed, silver mica, 200 μf , $\pm 5\%$, 500 vdcw Z* | 15-103 | 1 | | | |
| C2 | Capacitor: fixed, mica, 22 μf , $\pm 5\%$, 500 vdcw V* | 14-69 | 4 | | | |
| C3 | Capacitor: fixed, ceramic, .01 μf , tol. -0%, +100%, 1000 vdcw CC* | 15-43 | 4 | | | |
| C4 | Same as C2 | | | | | |
| C5 | Capacitor: fixed, mica, 39 μf , $\pm 5\%$, 300 vdcw V* | 14-70 | 2 | | | |
| C6 | Same as C2 | | | | | |
| C7 | Same as C3 | | | | | |
| C8 | Same as C2 | | | | | |
| C9 | Capacitor: fixed, ceramic, 20 μf , $\pm 10\%$, 500 vdcw CW* | 15-127 | 1 | | | |
| C10 | Capacitor: fixed, mica, 27 μf , $\pm 5\%$, 300 vdcw Z* | 14-78 | 4 | | | |
| C11 | Same as C3 | | | | | |
| C12 | Same as C10 | | | | | |
| C13 | Capacitor: fixed, mica, 47 μf , $\pm 5\%$, 300 vdcw V* | 14-74 | 1 | | | |
| C14 | Same as C10 | | | | | |
| C15 | Same as C3 | | | | | |
| C16 | Same as C10 | | | | | |
| C17 | Same as C5 | | | | | |
| C18 | Capacitor: fixed, mica, 30 μf , $\pm 5\%$, 300 vdcw Z* | 14-83 | 1 | | | |
| DS1 thru DS10 | Lamp, glow: 1/25 W, starting voltage 90 VDC (paired, aged) HP* | AC-4A-8 | 5 | | | |

* See "List of Manufacturers Code Letters For Replaceable Parts Table".

Total quantity used in the instrument.

TABLE OF REPLACEABLE PARTS

| CIRCUIT REF. | DESCRIPTION, MFR. * & MFR. DESIGNATION | Ⓢ STOCK NO. | # | | | |
|--------------|--|-------------|---------------|----|--|--|
| P1 | Connector, male: octal | HH* | 125-31 | 1 | | |
| R1 | Resistor: fixed, composition, 7.5 megohms, $\pm 5\%$, 1/2 W | B* | 23- 7.5M-5 | 1 | | |
| R2 | Resistor: fixed, composition, 18,000 ohms, $\pm 5\%$, 1 W | R* | 24- 18KR-5 | 2 | | |
| R3 | Resistor: fixed, composition, 10,000 ohms, $\pm 5\%$, 1/2 W | R* | 23- 10KR-5 | 2 | | |
| R4 | Resistor: fixed, composition, 240,000 ohms, $\pm 5\%$, 1/2 W | B* | 23- 240K-5 | 2 | | |
| R5 | Resistor: fixed, composition, 62,000 ohms, $\pm 5\%$, 1/2 W | B* | 23- 62K-5 | 3 | | |
| R6 | Resistor: fixed, composition, 8200 ohms, $\pm 5\%$, 1/2 W | B* | 23- 8200-5 | 2 | | |
| R7 | Resistor: fixed, composition, 220,000 ohms, $\pm 5\%$, 1/2 W | B* | 23- 220K-5 | 12 | | |
| R8 | Resistor: fixed, composition, 22,000 ohms, $\pm 5\%$, 1/2 W | R* | 25- 22KR-5 | 1 | | |
| R9 | Same as R7 | | | | | |
| R10 | Same as R2 | | | | | |
| R11 | Same as R3 | | | | | |
| R12 | Same as R4 | | | | | |
| R13 | Same as R5 | | | | | |
| R14 | Resistor: fixed, composition, 3 megohms, $\pm 1\%$, 1/2 W | NN* | 33-3M | 2 | | |
| R15 | Resistor: fixed, composition, 36,000 ohms, $\pm 5\%$, 1 W | R* | 24- 36KR-5 | 2 | | |
| R16 | Resistor: fixed, composition, 200,000 ohms, $\pm 5\%$, 1/2 W | B* | 23- 200K-5 | 3 | | |
| R17 | Resistor: fixed, composition, 75,000 ohms, $\pm 5\%$, 1/2 W | B* | 23- 75K-5 | 1 | | |
| R18 | Same as R6 | | | | | |

* See "List of Manufacturers Code Letters For Replaceable Parts Table".

Total quantity used in the instrument.

TABLE OF REPLACEABLE PARTS

| CIRCUIT REF. | DESCRIPTION, MFR. * & MFR. DESIGNATION | STOCK NO. | # | | | |
|--------------|--|-----------------|---|--|--|--|
| R19, 20 | Same as R7 | | | | | |
| R21 | Resistor: fixed, composition, 36,000 ohms, $\pm 5\%$, 2 W | B* 23-36K-5 (C) | 1 | | | |
| R22, 23 | Same as R7 | | | | | |
| R24 | Same as R15 | | | | | |
| R25 | Same as R16 | | | | | |
| R26 | Same as R5 | | | | | |
| R27 | Same as R14 | | | | | |
| R28 | Resistor: fixed, composition, 47,000 ohms, $\pm 5\%$, 1/2 W | R* 23-47KR-5 | 4 | | | |
| R29 | Resistor: fixed, composition, 270,000 ohms, $\pm 5\%$, 1/2 W | B* 23-270K-5 | 4 | | | |
| R30 | Resistor: fixed, composition, 100,000 ohms, $\pm 5\%$, 1/2 W | B* 23-100K-5 | 6 | | | |
| R31 | Resistor: fixed, composition, 15,000 ohms, $\pm 5\%$, 1/2 W | B* 23-15K-5 | 2 | | | |
| R32 | Same as R7 | | | | | |
| R33 | Resistor: fixed, composition, 47,000 ohms, $\pm 5\%$, 1 W | R* 24-47KR-5 | 1 | | | |
| R34 | Same as R7 | | | | | |
| R35 | Same as R28 | | | | | |
| R36 | Same as R29 | | | | | |
| R37 | Same as R30 | | | | | |
| R38 | Resistor: fixed, deposited carbon, 1.5 megohms, $\pm 1\%$, 1/2 W | NN* 33-1.5M | 1 | | | |
| R39 | Same as R28 | | | | | |
| R40 | Same as R29 | | | | | |
| R41 | Same as R30 | | | | | |
| R42 | Same as R31 | | | | | |

* See "List of Manufacturers Code Letters For Replaceable Parts Table".

Total quantity used in the instrument.

TABLE OF REPLACEABLE PARTS

| CIRCUIT REF. | DESCRIPTION, MFR. * & MFR. DESIGNATION | STOCK NO. | # | | | |
|----------------------|--|-----------------|---|--|--|--|
| R43, 44 | Same as R7 | | | | | |
| R45 | Resistor: fixed, composition, 47,000 ohms, $\pm 5\%$, 1 W | B* 24-47K-5 (C) | 1 | | | |
| R46, 47 | Same as R7 | | | | | |
| R48 | Same as R28 | | | | | |
| R49 | Same as R29 | | | | | |
| R50, 51, 52 | Same as R30 | | | | | |
| R53, 54 | Resistor: fixed, composition, 68,000 ohms, $\pm 10\%$, 1/2 W Electrical value adjusted at factory | B* 23-68K | 2 | | | |
| R55 | Same as R16 Electrical value adjusted at factory | | | | | |
| V1, 2, 3, 4 | Tube, electron: 5963 | ZZ* 212-5963 | 4 | | | |
| <u>MISCELLANEOUS</u> | | | | | | |
| | Clamp, tube: 1" Universal Metal Prod. | 140-12 | 4 | | | |
| | Plate, numeral | HP* AC-4A-6 | 1 | | | |
| | Socket, tube: 9 contact | AE* 120-10 | 4 | | | |

* See "List of Manufacturers Code Letters For Replaceable Parts Table".

Total quantity used in the instrument.

LIST OF CODE LETTERS USED IN TABLE OF REPLACEABLE PARTS TO DESIGNATE THE MANUFACTURERS

| CODE LETTER | MANUFACTURER | ADDRESS | CODE LETTER | MANUFACTURER | ADDRESS |
|-------------|--|-------------------------|-------------|-----------------------------------|------------------------|
| A | Aerovox Corp. | New Bedford, Mass. | AK | Hammerlund Mfg. Co., Inc. | New York 1, N. Y. |
| B | Allen-Bradley Co. | Milwaukee 4, Wis. | AL | Industrial Condenser Corp. | Chicago 18, Ill. |
| C | Amperite Co. | New York, N. Y. | AM | Insuline Corp. of America | Manchester, N. H. |
| D | Arrow, Hart & Hegeman | Hartford, Conn. | AN | Jennings Radio Mfg. Corp. | San Jose, Calif. |
| E | Bussman Manufacturing Co. | St. Louis, Mo. | AO | E. F. Johnson Co. | Waseca, Minn. |
| F | Carborundum Co. | Niagara Falls, N. Y. | AP | Lenz Electric Mfg. Co. | Chicago 47, Ill. |
| G | Centralab | Milwaukee 1, Wis. | AQ | Micro-Switch | Freeport, Ill. |
| H | Cinch-Jones Mfg. Co. | Chicago 24, Ill. | AR | Mechanical Industries Prod. Co. | Akron 8, Ohio |
| HP | Hewlett-Packard Co. | Palo Alto, Calif. | AS | Model Eng. & Mfg., Inc. | Huntington, Ind. |
| I | Clarostat Mfg. Co. | Dover, N. H. | AT | The Muter Co. | Chicago 5, Ill. |
| J | Cornell Dubilier Elec. Co. | South Plainfield, N. J. | AU | Ohmite Mfg. Co. | Skokie, Ill. |
| K | Hi-Q Division of Aerovox | Olean, N. Y. | AV | Resistance Products Co. | Harrisburg, Pa. |
| L | Erie Resistor Corp. | Erie 6, Pa. | AW | Radio Condenser Co. | Camden 3, N. J. |
| M | Fed. Telephone & Radio Corp. | Clifton, N. J. | AX | Shallcross Manufacturing Co. | Collingdale, Pa. |
| N | General Electric Co. | Schenectady 5, N. Y. | AY | Solar Manufacturing Co. | Los Angeles 58, Calif. |
| O | General Electric Supply Corp. | San Francisco, Calif. | AZ | Sealectro Corp. | New Rochelle, N. Y. |
| P | Girard-Hopkins | Oakland, Calif. | BA | Spencer Thermostat | Attleboro, Mass. |
| Q | Industrial Products Co. | Danbury, Conn. | BC | Stevens Manufacturing Co. | Mansfield, Ohio |
| R | International Resistance Co. | Philadelphia 8, Pa. | BD | Torrington Manufacturing Co. | Van Nuys, Calif. |
| S | Lectrohm Inc. | Chicago 20, Ill. | BE | Vector Electronic Co. | Los Angeles 65, Calif. |
| T | Littlefuse Inc. | Des Plaines, Ill. | BF | Weston Electrical Inst. Corp. | Newark 5, N. J. |
| U | Maguire Industries Inc. | Greenwich, Conn. | BG | Advance Electric & Relay Co. | Burbank, Calif. |
| V | Micamold Radio Corp. | Brooklyn 37, N. Y. | BH | E. I. DuPont | San Francisco, Calif. |
| W | Oak Manufacturing Co. | Chicago 10, Ill. | BI | Electronics Tube Corp. | Philadelphia 18, Pa. |
| X | P. R. Mallory Co., Inc. | Indianapolis, Ind. | BJ | Aircraft Radio Corp. | Boonton, N. J. |
| Y | Radio Corp. of America | Harrison, N. J. | BK | Allied Control Co., Inc. | New York 21, N. Y. |
| Z | Sangamo Electric Co. | Marion, Ill. | BL | Augat Brothers, Inc. | Attleboro, Mass. |
| AA | Sarkes Tarzian | Bloomington, Ind. | BM | Carter Radio Division | Chicago, Ill. |
| BB | Signal Indicator Co. | Brooklyn 37, N. Y. | BN | CBS Hytron Radio & Electric | Danvers, Mass. |
| CC | Sprague Electric Co. | North Adams, Mass. | BO | Chicago Telephone Supply | Elkhart, Ind. |
| DD | Stackpole Carbon Co. | St. Marys, Pa. | BP | Henry L. Crowley Co., Inc. | West Orange, N. J. |
| EE | Sylvania Electric Products Co. | Warren, Pa. | BQ | Curtiss-Wright Corp. | Carlstadt, N. J. |
| FF | Western Electric Co. | New York 5, N. Y. | BR | Allen B. DuMont Labs | Clifton, N. J. |
| GG | Wilkor Products, Inc. | Cleveland, Ohio | BS | Excel Transformer Co. | Oakland, Calif. |
| HH | Amphenol | Chicago 50, Ill. | BT | General Radio Co. | Cambridge 39, Mass. |
| II | Dial Light Co. of America | Brooklyn 37, N. Y. | BU | Hughes Aircraft Co. | Culver City, Calif. |
| JJ | Leecraft Manufacturing Co. | New York, N. Y. | BV | International Rectifier Corp. | El Segundo, Calif. |
| KK | Switchcraft, Inc. | Chicago 22, Ill. | BW | James Knights Co. | Sandwich, Ill. |
| LL | Gremar Manufacturing Co. | Wakefield, Mass. | BX | Mueller Electric Co. | Cleveland, Ohio |
| MM | Carad Corp. | Redwood City, Calif. | BY | Precision Thermometer & Inst. Co. | Philadelphia 30, Pa. |
| NN | Electra Manufacturing Co. | Kansas City, Mo. | BZ | Radio Essentials Inc. | Mt. Vernon, N. Y. |
| OO | Acro Manufacturing Co. | Columbus 16, Ohio | CA | Raytheon Manufacturing Co. | Newton, Mass. |
| PP | Alliance Manufacturing Co. | Alliance, Ohio | CB | Tung-Sol Lamp Works, Inc. | Newark 4, N. J. |
| QQ | Arco Electronics, Inc. | New York 13, N. Y. | CD | Varian Associates | Palo Alto, Calif. |
| RR | Astron Corp. | East Newark, N. J. | CE | Victory Engineering Corp. | Union, N. J. |
| SS | Axel Brothers Inc. | Long Island City, N. Y. | CF | Weckesser Co. | Chicago 30, Ill. |
| TT | Belden Manufacturing Co. | Chicago 44, Ill. | CG | Wilco Corporation | Indianapolis, Ind. |
| UU | Bird Electronics Corp. | Cleveland 14, Ohio | CH | Winchester Electronics, Inc. | Santa Monica, Calif. |
| VV | Barber Colman Co. | Rockford, Ill. | CI | Malco Tool & Die | Los Angeles 42, Calif. |
| WW | Bud Radio Inc. | Cleveland 3, Ohio | CJ | Oxford Electric Corp. | Chicago 15, Ill. |
| XX | Allen D. Cardwell Mfg. Co. | Plainville, Conn. | CK | Camloc-Fastener Corp. | Paramus, N. J. |
| YY | Cinema Engineering Co. | Burbank, Calif. | CL | George K. Garrett | Philadelphia 34, Pa. |
| ZZ | Any brand tube meeting RETMA standards. | | CM | Union Switch & Signal | Swissvale, Pa. |
| AB | Corning Glass Works | Corning, N. Y. | CN | Radio Receptor | New York 11, N. Y. |
| AC | Dale Products, Inc. | Columbus, Neb. | CO | Automatic & Precision Mfg. Co. | Yonkers, N. Y. |
| AD | The Drake Mfg. Co. | Chicago 22, Ill. | CP | Bassick Co. | Bridgeport 2, Conn. |
| AE | Elco Corp. | Philadelphia 24, Pa. | CQ | Birnbach Radio Co. | New York 13, N. Y. |
| AF | Hugh H. Eby Co. | Philadelphia 44, Pa. | CR | Fischer Specialties | Cincinnati 6, Ohio |
| AG | Thomas A. Edison, Inc. | West Orange, N. J. | CS | Telefunken (c/o MVM, Inc.) | New York, N. Y. |
| AH | Fansteel Metallurgical Corp. | North Chicago, Ill. | CT | Potter-Brumfield Co. | Princeton, Ind. |
| AI | General Ceramics & Steatite Corp. | Keasbey, N. J. | CU | Cannon Electric Co. | Los Angeles, Calif. |
| AJ | The Gudeman Co. | Sunnyvale, Calif. | CV | Dynac, Inc. | Palo Alto, Calif. |
| | | | CW | Good-All Electric Mfg. Co. | Ogallala, Nebr. |

CLAIM FOR DAMAGE IN SHIPMENT

The instrument should be tested as soon as it is received. If it fails to operate properly, or is damaged in any way, a claim should be filed with the carrier. A full report of the damage should be obtained by the claim agent, and this report should be forwarded to us. We will then advise you of the disposition to be made of the equipment and arrange for repair or replacement. Include model number and serial number when referring to this instrument for any reason.

WARRANTY

Hewlett-Packard Company warrants each instrument manufactured by them to be free from defects in material and workmanship. Our liability under this warranty is limited to servicing or adjusting any instrument returned to the factory for that purpose and to replace any defective parts thereof. Klystron tubes as well as other electron tubes, fuses and batteries are specifically excluded from any liability. This warranty is effective for one year after delivery to the original purchaser when the instrument is returned, transportation charges prepaid by the original purchaser, and when upon our examination it is disclosed to our satisfaction to be defective. If the fault has been caused by misuse or abnormal conditions of operation, repairs will be billed at cost. In this case, an estimate will be submitted before the work is started.

If any fault develops, the following steps should be taken:

1. Notify us, giving full details of the difficulty, and include the model number and serial number. On receipt of this information, we will give you service data or shipping instructions.
2. On receipt of shipping instructions, forward the instrument prepaid, to the factory or to the authorized repair station indicated on the instructions. If requested, an estimate of the charges will be made before the work begins provided the instrument is not covered by the warranty.

SHIPPING

All shipments of Hewlett-Packard instruments should be made via Truck or Railway Express. The instruments should be packed in a strong exterior container and surrounded by two or three inches of excelsior or similar shock-absorbing material.

DO NOT HESITATE TO CALL ON US

HEWLETT-PACKARD COMPANY

Laboratory Instruments for Speed and Accuracy

275 PAGE MILL ROAD

CABLE



PALO ALTO, CALIF. U.S.A.

"HEWPACK"



APPLICATION NOTES

hp MODEL AC-4A

DECADE COUNTER

RETURN TO
E. E. INSTRUCTION MANUAL FILE

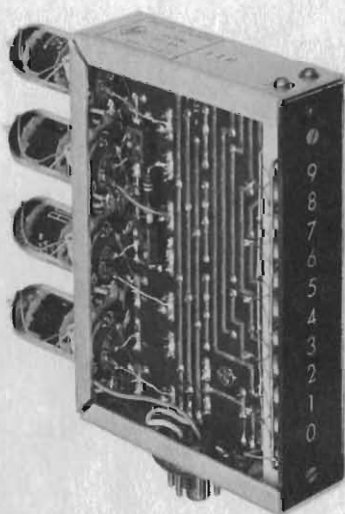

CONTENTS:

- A. Block Diagram of Simple Electronic Counter.
- B. AC-4A in Basic Electronic Counter Circuit.
- C. Driving Circuit for AC-4A.
- D. Remote Readout Circuits for Use with AC-4A.
- E. Reset Circuits for Use with AC-4A.

10D Z111

A. BLOCK DIAGRAM OF SIMPLE ELECTRONIC COUNTER

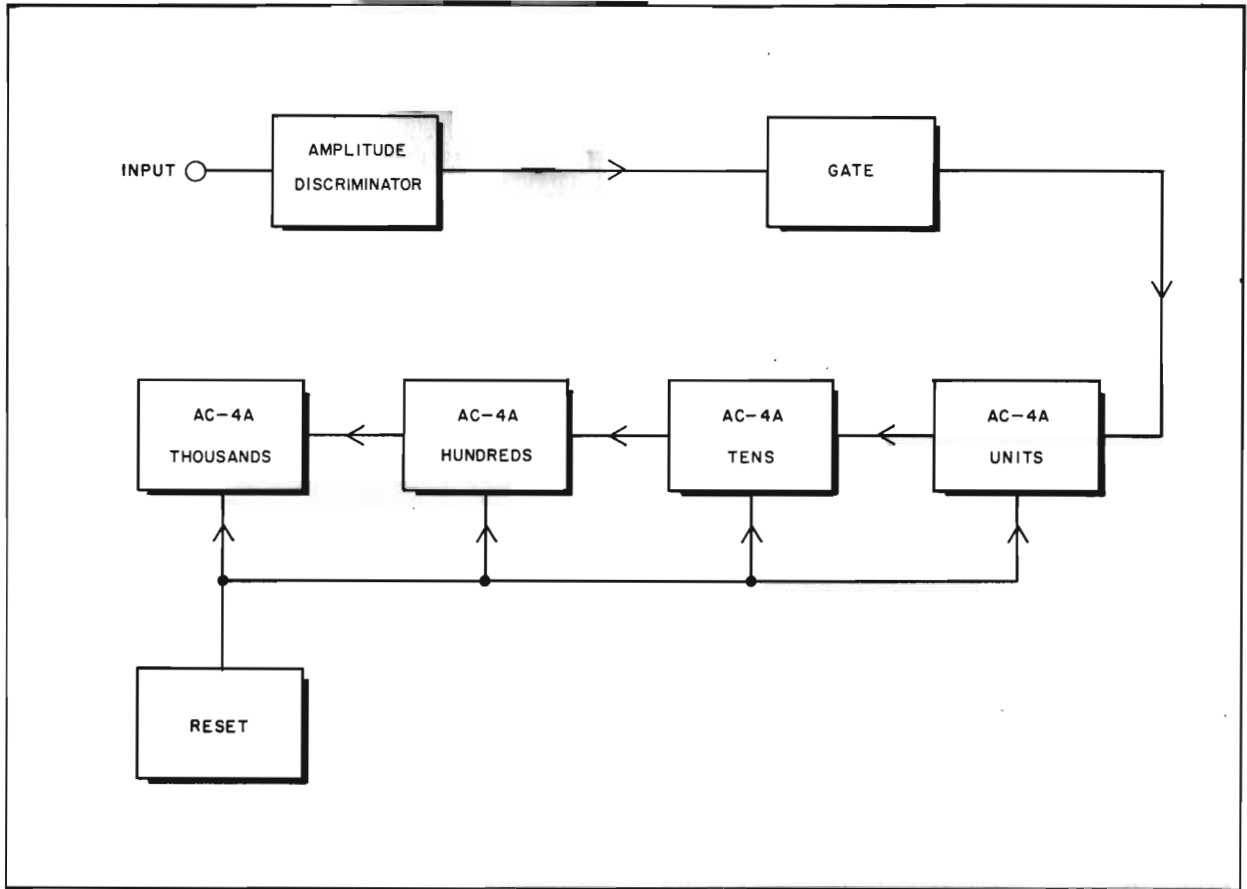

Fig. 1. Block Diagram of Basic Electronic Counter

Fig. 1 is a block diagram of an electronic counter, which consists of the following sections:

AMPLITUDE DISCRIMINATOR, which connects to the INPUT voltage to be counted. From this signal input, which may be a sine wave, square wave, or pulse, the Amplitude Discriminator develops the required driving pulse for the first AC-4A Decade Counter. The output pulse of the Amplitude Discriminator is of the same amplitude and rise time regardless of the amplitude and rise time of the signal to the INPUT.

GATE, which in its simplest form is an ON-OFF switch connected between the output of the Amplitude Discriminator and the first AC-4A Decade

Counter. The Amplitude Discriminator puts out pulses as long as it receives an input of sufficient amplitude; however, pulses cannot operate the AC-4A Decade Counters unless the GATE is closed. This GATE may be a simple ON-OFF switch as shown in Fig. 2, a pair of relay contacts, a vacuum tube biased in and out of cut-off, a diode arrangement or other circuit configuration, depending upon the speed and accuracy requirements placed on the GATE by the application.

AC-4A DECADE COUNTERS, which count all pulses from the Amplitude Discriminator when the GATE is OPEN. When the GATE is CLOSED, the AC-4A's remain indefinitely on the last count received and display the total as one numeral in each decade illuminated by a neon lamp. The output of one AC-4A Decade Counter will drive the input of the next without additional circuitry.

RESET. It is usually desirable to return all AC-4A's to zero before beginning a new count. All AC-4A's can be reset to zero simultaneously with a RESET switch as shown in Fig. 2, or in automatic counting equipment this can be done with a thyatron circuit as shown in Fig. 8 or Fig. 9.

B. AC-4A IN BASIC COUNTER CIRCUIT

Fig. 2 is a schematic circuit of the counter in Fig. 1. The Amplitude Discriminator can be built following the circuit in Fig. 3 (Schematic Diagram Amplitude Discriminator Unit for Model 522A/B). This Amplitude Discriminator is available from Hewlett-Packard Company as a plug-in unit -hp- Part No. 522B-58B. The GATE is a manually operated switch but could be a pair of relay contacts. Counters are RESET to zero with a manual pushbutton. The power supply should be able to furnish +300 volts at 15 ma and 6.3v ac at 1.2 amps for each AC-4A used, in addition to +210v regulated at 10 ma, -105v regulated at 3 ma, and 6.3v at .6 amp for the Amplitude Discriminator.

This counter will count at a maximum rate of 120 kc or more and the total number of digits displayed is limited only by the number of AC-4A's used.

To adjust R12:

- a. Connect a 1000 cps sine wave to the input of the Amplitude Discriminator (Fig. 2).
- b. Observe the output at Pin 1 with a scope or observe the AC-4A Counters for steady operation.
- c. Decrease amplitude of 1000 cps input.
- d. Adjust R12 for a symmetrical square wave or for steady operation of the AC-4A Counters.
- e. Repeat above steps until the minimum input voltage is reached.
- f. This is the correct setting of the sensitivity control for best operation at all input voltages and frequencies.

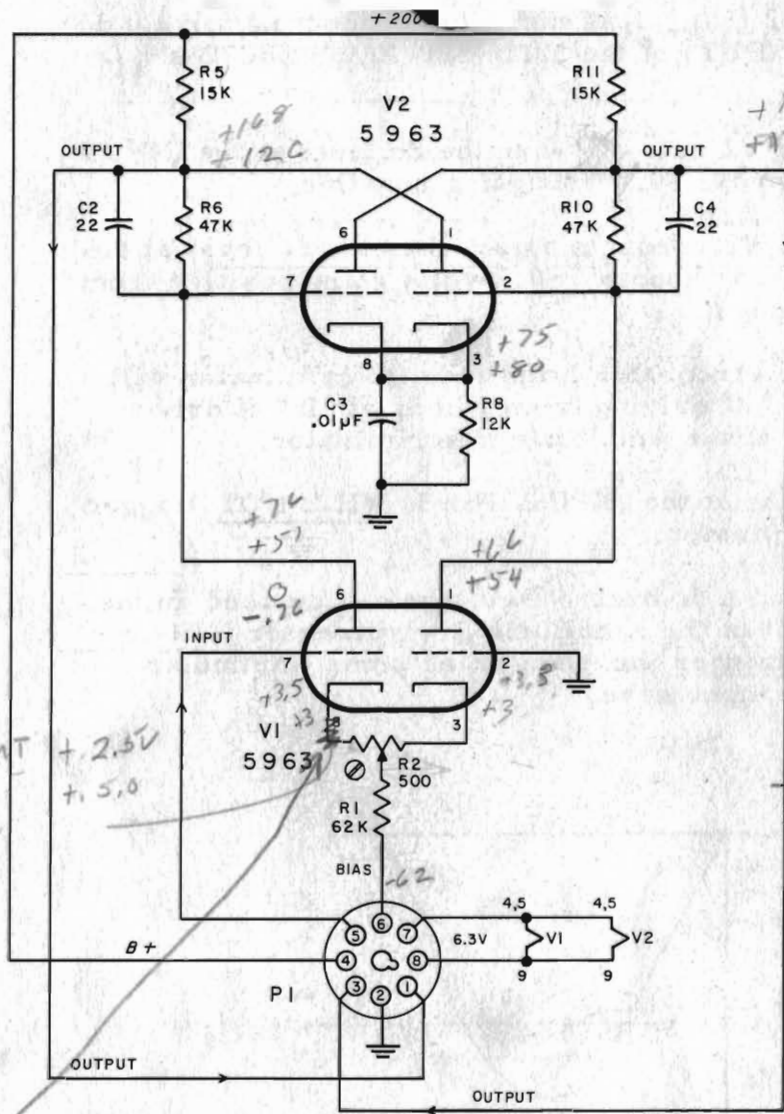

COPYRIGHT 1954 BY HEWLETT-PACKARD COMPANY
 This drawing is intended for the operation and maintenance of Hewlett-Packard equipment and is not to be used otherwise or reproduced without written consent of the Hewlett-Packard Company.

add
 3.3 K 1/2w.
 in series
 with pin 8

SCHEMATIC DIAGRAM AMPLITUDE DISCRIMINATOR UNIT

 STOCK NUMBER 522B-58-B

Figure 3.



C. DRIVING CIRCUIT FOR AC-4A

Triggering of the Amplitude Discriminator is at the approximate dc levels shown below when connected as in Fig. 2.

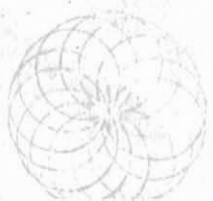
PLATE Pin 1 V2 (Fig. 3) is normally conducting for 0 v dc on Pin 5 (INPUT) of the 522B-58B Amplitude Discriminator.

PLATE Pin 1 of V2 cuts off when the dc level at the INPUT crosses approx. -0.4 volt going negative.

PLATE Pin 1 of V2 conducts again when the dc level at the INPUT crosses approx. -0.2 volts going positive from a negative peak.

An AC-4A driven from this Amplitude Discriminator will count at "A" if driving from Pin 3, at "B" if driven from Pin 1 of the Amplitude Discriminator.

Positive dc levels at the INPUT (Pin 5) WILL NOT trigger this discriminator.

An attenuator and a dc buck out voltage can be used in the input circuit of the Amplitude Discriminator if it is desired to trigger the counter at some particular place on an input wave.

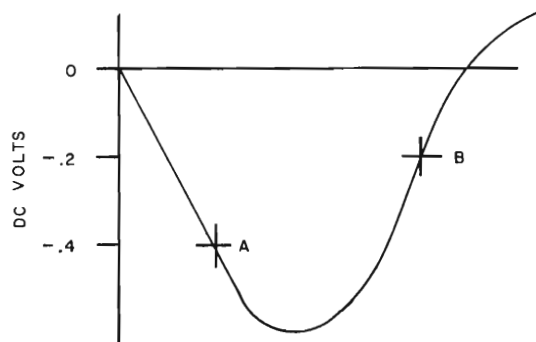

Fig. 4. Trigger Levels of the 522B-58B Amplitude Discriminator Connected as in Fig. 1

D. REMOTE READOUT CIRCUITS FOR USE WITH AC-4A

The staircase output voltage from base Pin 8 of the AC-4A Decade Counter Units is a dc voltage proportional to the digit indicated by the AC-4A.

This voltage can be used to operate printing systems using coincidence detectors or can be read out on remotely located dc meters or ink recorders using the circuits shown in Fig. 6 or Fig. 7.

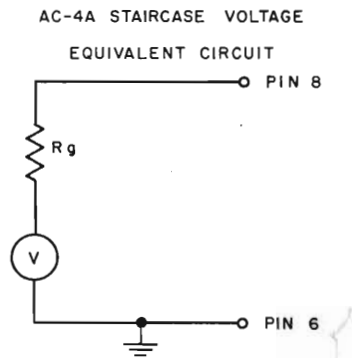

Fig. 5. Staircase Equivalent Circuit

Staircase voltage output is between base Pin 8 and GND.

The load on the staircase output, including a short, has no effect on operation of AC-4A Counter.

R_g - Approx. 700k

V - +135v count of 0 to +55v count of 9 in approximately equal steps.
Tolerance on any step is ± 1 volt.

The staircase output voltage will vary with the unregulated +300 volt supply to the AC-4A's.

The staircase voltage can be +55 volts at count of ZERO, +135 volts at the count of NINE if R14, R14, R27, and R38 in the Schematic Diagram of Model AC-4A Decade Counter are all changed to the opposite plate in each binary.

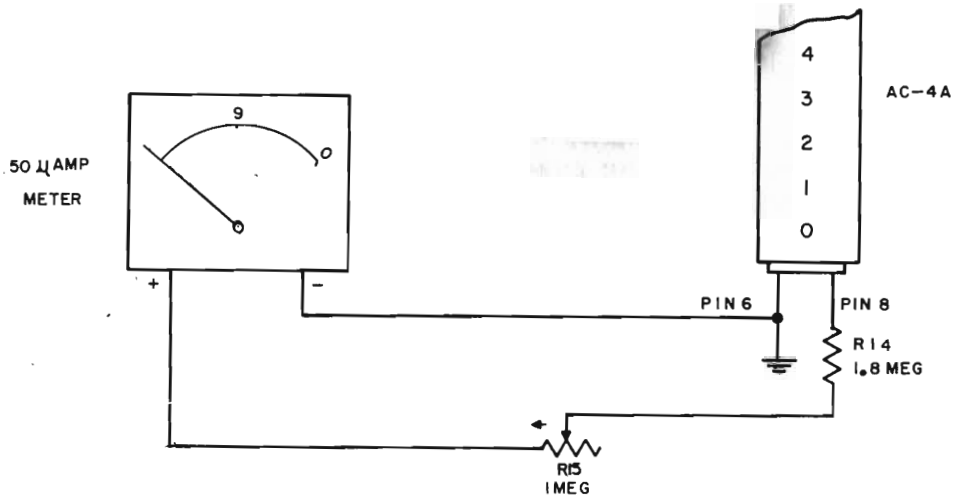

Fig. 6. Remote Readout of AC-4A Using Ground Return for Meter

1. Reset AC-4A to ZERO.
2. Adjust R15 for full scale deflection of meter.
3. Step AC-4A one digit at a time and mark meter scale.

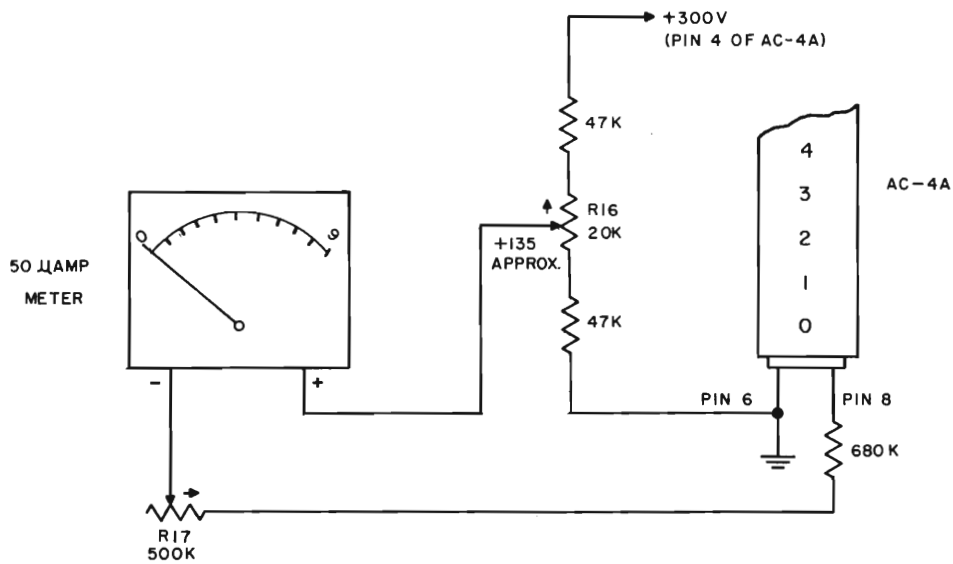

Fig. 7. Remote Readout of AC-4A Decade Counter Unit
Using a Circuit that Supplies a DC "Bucking"
Voltage to Permit Use of a Standard Meter

1. Reset AC-4A to ZERO.
2. Adjust R16 for 0 reading on meter.
3. Stop AC-4A on 9.
4. Adjust R17 for full scale reading on meter.
5. Reset AC-4A to ZERO.
6. Step AC-4A one digit at a time and mark meter scale.

E. RESET CIRCUITS FOR USE WITH THE AC-4A

In automatic electronic counting equipment it is usually desirable to reset the Decade Counters with an electrical pulse rather than with a manual switch. The circuit in Fig. 8 will reset all AC-4A Decade Counters to ZERO simultaneously if a positive pulse is applied to the INPUT of the 2D21 Reset Thyatron. Depressing the MANUAL RESET will also return all decade to ZERO.

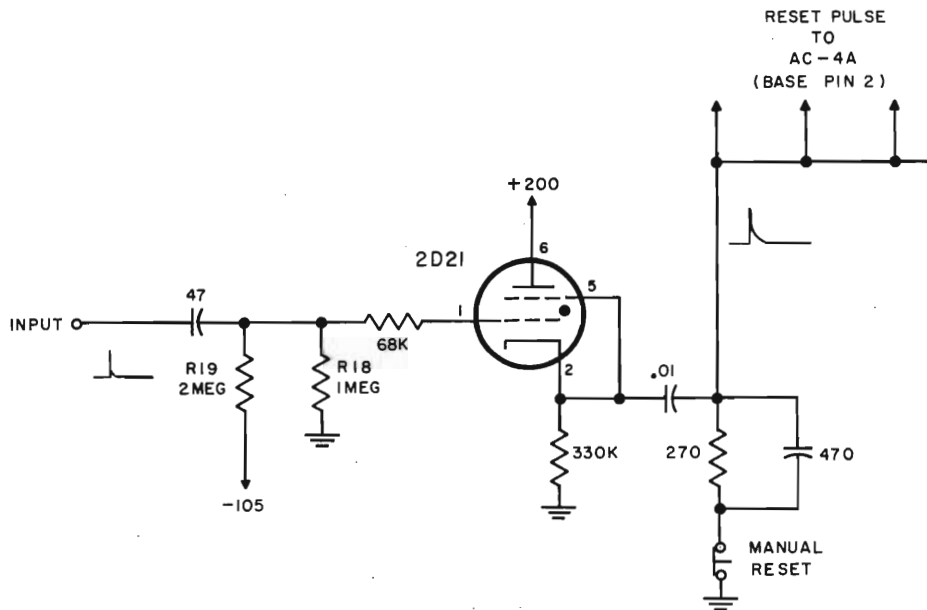

Fig. 8. Circuit to Reset AC-4A Decade Counters to Zero

NOTE:

A positive pulse at the input to this circuit delivers a 150 volt positive reset pulse with fast rise and slow fall to reset all AC-4A Decade Counters to ZERO simultaneously. This circuit will function if R19 is removed and R18 is returned to approximately -30 volts. Smaller negative voltages than -30 will enable the reset thyatron to be triggered by a lower amplitude positive pulse but will also make it more susceptible to stray pulses from other circuits.

Resetting all Decade Counters to NINE (or more properly -1) may be desirable if the operation of a gate circuit puts an extra pulse into the counter circuits. A manual pushbutton used with this circuit should be connected to supply a positive pulse to the INPUT of the Reset Thyatron.

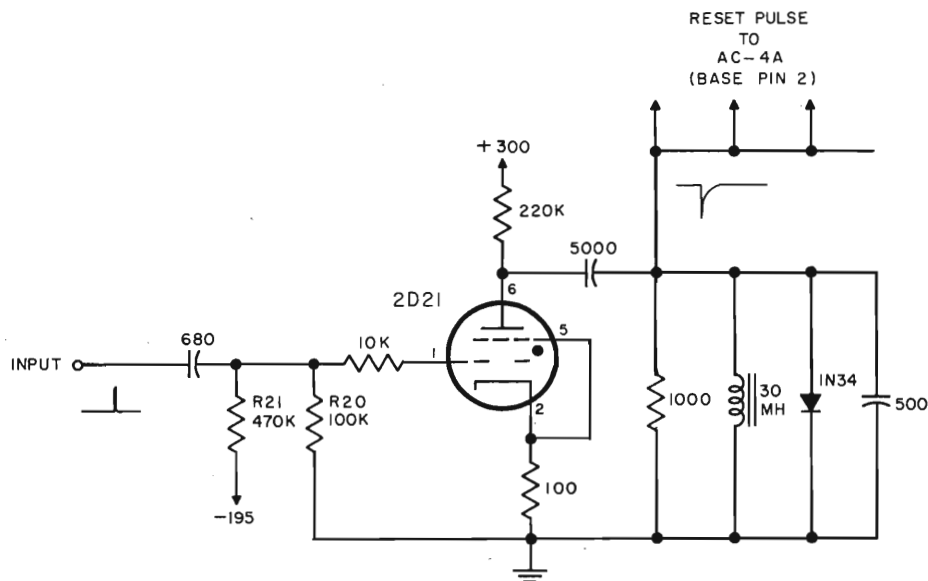

Fig. 9. Circuit to Reset AC-4A Decade Counter Units to Nine

NOTE:

A positive pulse at the input to this circuit delivers a 200. volt negative reset pulse with fast fall and slow rise to reset all AC-4A Decade Counters to NINE simultaneously. This circuit will function if R21 is removed and R20 is returned to approximately -30 volts.

The AC-4A can be reset to NINE with a manual pushbutton if the leads connecting the GND and RESET buses to the base plug are reversed where they join the printed circuit board. Refer to the reset circuit of Fig. 8 for details.